

**EFFICIENT VENTILATION:
DISPLACEMENT VENTILATION AND
AIR CURTAIN ZONING**

Håkon Skistad, M.Sc.,
Senior Researcher,
SINTEF Energiforskning AS
Kolbj. Hejesvei 1D
NO 7465 Trondheim
Norway
hakon.skistad@sintef.no

SUMMARY

Displacement Ventilation with thermal stratification has been developed for non-industrial premises since the early 1980's. After an enthusiastic start, the market for Displacement Ventilation in Scandinavia has matured and stabilised. Several benefits have been proved, but also, there have been faulty designs and installations. This presentation gives an overview of the principles, possibilities and limitations.

The aim of developing displacement ventilation was to achieve a more efficient system. In some cases, however, like with tobacco smoking in crowded spaces, we have to think differently to achieve the most efficient ventilation. This has led to the use of establishing separate zones within one room, without walls to separate the zones. Air curtains are used to help separating the zones. Currently, there are two prototype installations; one in a combined bar and restaurant in Trondheim and one in a bar on a car ferry. Nicotine tests have shown that the installations protect the employees and the non-smoking guests within the TLV-values that are in force by the government.

1 INTRODUCTION

Historically, ventilation in the Nordic countries has always been displacement ventilation driven by buoyancy, with more or less thermal stratification inside the rooms. In non-industrial premises, this was so until the modern ventilation techniques entered the stage and made ventilation synonymous with mixing the air in the room. In industrial premises, natural ventilation with displacement effects remained in parallel with mechanically driven ventilation and various ventilation principles.

In Trondheim, we started investigating displacement ventilation for use in aluminium electrolysis rooms in the early 1970's. In the following years, we investigated other industries, and found design criteria for the ventilation of several industries. Now, in 2003, most heavy industrial premises are ventilated by displacement ventilation according to the design criteria that have been developed.

In the early 1980's, we took a closer look at the ventilation of non-industrial premises. Studying how tobacco smoke rose above the smokers, we wondered if we could utilise the same principle in non-commercial premises as in furnace rooms. Theory and practice went side by side, and very soon we have made the first installations. The smoke tests of convection currents above people and computers were convincing. The temperature distribution was somewhat different from what we had expected. The temperature increased linearly with height, instead of creating a colder layer in the occupied zone and a warm layer below the ceiling.

People soon reported about improved air quality in the premises ventilated by displacement ventilation, and the new principle became very popular. In the late '80's many displacement ventilation systems were made. Unfortunately, many of the installations were not properly

designed and installed, and displacement ventilation got a reputation of giving draught along the floor, and making people get cold feet. In the 1990's things seemed to have matured, displacement ventilation and mixing ventilation are used according to the type of ventilation problem.

The trend now seems to be that we ask for the most efficient ventilation system, rather than asking for displacing or mixing system. This has lead us in the direction of creating zones of different air quality inside rooms. One means of separating the zones is to use air curtains.

2 NOMENCLATURE

The following nomenclature appear in some of the figures:

$Q =$ heating [W]

$\theta_e =$ extract air temperature [$^{\circ}\text{C}$]

$\theta_{oz} =$ temperature in the occupied zone, 1,1 metres above the floor [$^{\circ}\text{C}$]

$\theta_s =$ supply air temperature [$^{\circ}\text{C}$]

3 DISPLACEMENT VENTILATION

3.1 The idea

Displacement ventilation can in principle be any airflow pattern where “old” air is displaced by “new” air. By Displacement Ventilation, as commonly used in ventilation, we understand the technique of letting warm contaminants rise to the ceiling, extract the contaminated air at ceiling level and supply fresh, cool air at floor level. See Figure 1.

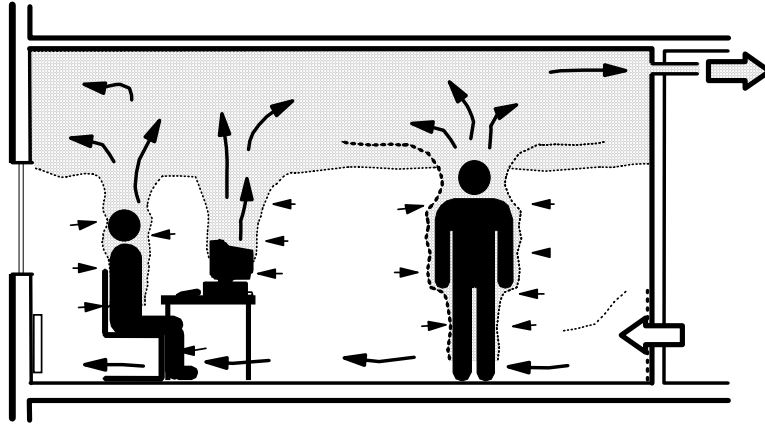

Figure 1 The idea of displacement ventilation.

3.2 Rehva Guidebook #1

In 1999 Rehva decided to make a guidebook on displacement ventilation in non-industrial premises (1). The book points out for what cases displacement ventilation is well suited, and for what cases it is less suited. It deals with the importance of choosing the right supply units, and how to avoid draught along the floor, as well as energy aspects.

For more details about the theory behind this ventilation principle and some case studies, we recommend that you see this book. In the following paragraphs, we shall take a look at some aspects of displacement ventilation principle.

3.3 Airflow rates and flow patterns

Usually, we find that both mixing and displacement systems require about the same airflow rates, but displacement ventilation usually gives a better air quality for the same amount of ventilating air. Laboratory tests indicate that displacement ventilation may work with lower ventilation rates than mixing ventilation. When very low ventilation rates and large under-temperatures are used, mixing ventilation will in most cases be preferable.

The mechanism behind displacement ventilation is to supply as much air per person as is entrained in the convection flow around the person (or other convective sources). In practice, we say that this flow rate is 20 l/s. See Figure 2.

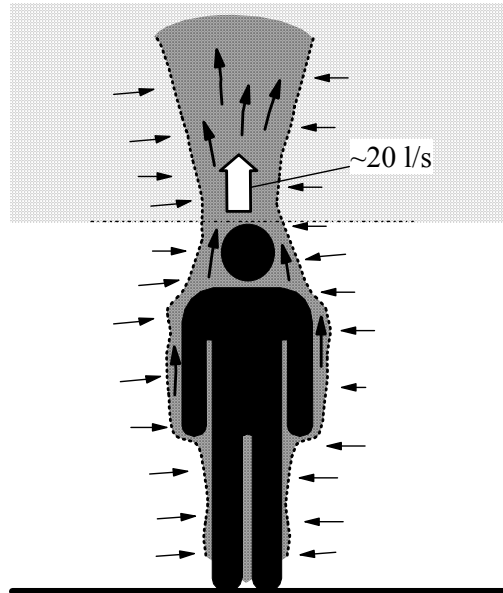

Figure 2 Air volume flow in the plume above a person.

In this way the contaminated air is brought up into the layer above people. The total ventilation rate should equal the sum of the airflow rates in the plumes above the people and other convective sources in the room. Then we might get an airflow pattern as shown to the left in Figure 3, with contaminated air stratifying above the head of the people in the room.

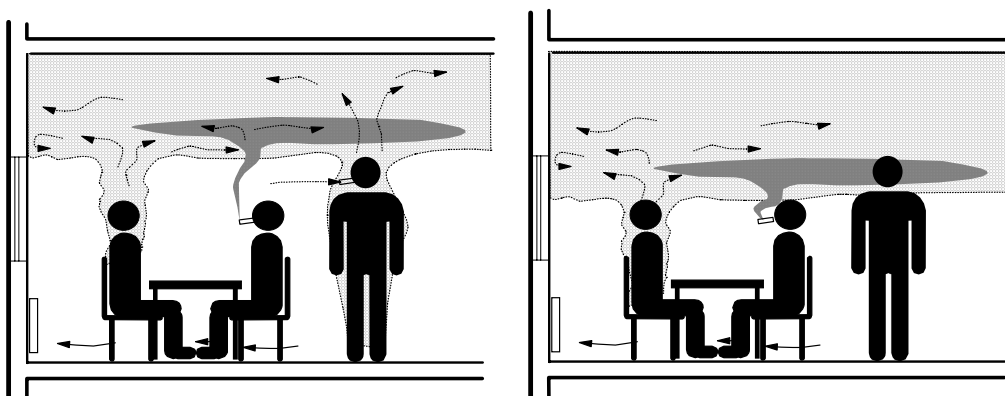

Figure 3 Airflow patterns for various air volume flows.

When the airflow per person is less than, say 15 l/s, the convection flow around the person may stratify around or below the head height of people. See the right hand side of Figure 3. Then, we may ask whether any air quality benefit is achieved. One answer to that problem has been suggested by Etheridge and Sandberg (7). They have pointed out that the air flowing around a person is taken from below. They found contaminant concentrations in the inhalation air to be merely about 20% of the contaminant concentrations in the air at the same level around a person.

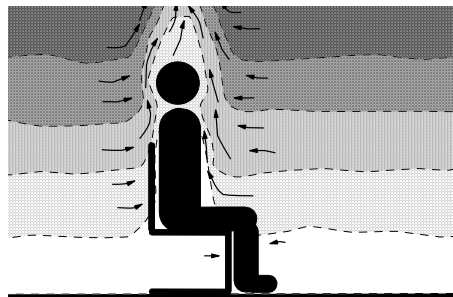

Figure 4 The rising airflow around a person brings fresh air up to the breathing zone.

The measurements by Etheridge and Sandberg have been made in laboratory with manikins at rest. When people are moving, we cannot expect the same favourable airflow pattern. It should be mentioned, however, that feedback from people in practice support the findings of Etheridge and Sandberg.

3.4 No cold feet, please!

Attention must be paid to the temperature close to the floor. In practice, this means that when the air is supplied with under-temperature, one has to choose a diffuser with the right amount of mixing between the room air and the supply air. The air velocity near the diffuser may also create problems when induction rates are high.

3.5 The occupied zones – the coolest part of the room

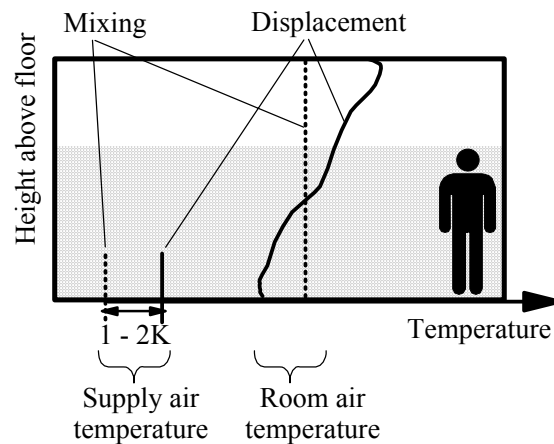

Figure 5 Typical vertical temperature distributions, displacement and mixing ventilation.

In displacement ventilation, the air temperature increases from floor to ceiling. This means that the occupied spaces are the coolest part of the room. Compared to mixing ventilation, the supply air temperature is about 1 - 2K lower for a room height of 3 metres, and up to 4K for tall rooms.

This implies longer periods of the year where free cooling can be applied, and less energy consumption for cooling of the supply air.

3.6 Room heating with displacement ventilation

The general rule for displacement ventilation is: “Don’t heat the room by the ventilation air.”

So, how should we do it? Generally, there are three different means of room heating that are used together with displacement ventilation:

- Floor heating
- Radiant heating
- Convectors

Heating the room by warm air is generally avoided, but may be used as supplement for heating the room at the start of the working day, or for rapid heating after the room has been

opened to the cold outside air. This means that the room may be heated by the ventilation air in cases where air quality or ventilation efficiency is not important.

Too much floor heating may theoretically heat the supply air so much that the air ascends due to buoyancy, thereby destroying the displacement airflow pattern. In practice this does not occur for normal heat loads.

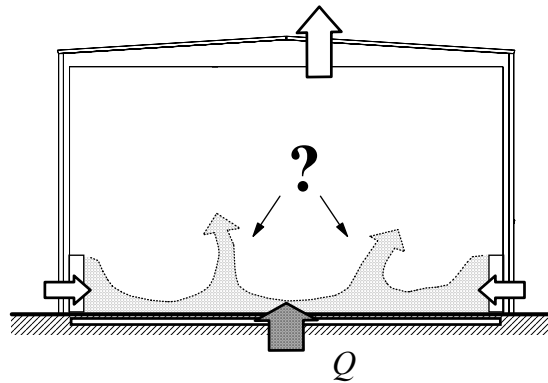

Figure 6 In practice, floor heating is not does not destroy the displacement ventilation pattern.

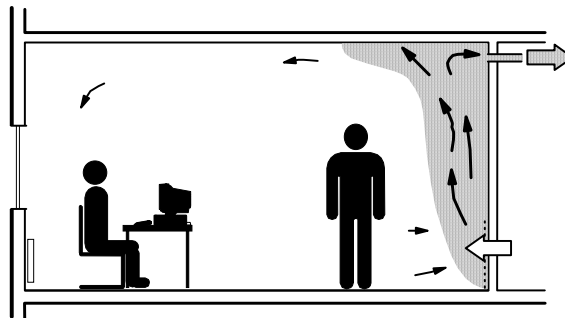

Figure 7 Supply of warm ventilation air means short-circuiting.

If warm air is supplied at floor level in a cold room, the warm, fresh air will rise due to buoyancy, and be extracted when it reaches the ceiling. Thus, the fresh air will short circuit into the outlet openings and little of the fresh air will reach the occupied spaces.

4 DISPLACEMENT VENTILATION – NOT ALWAYS THE BEST

One might think that Displacement Ventilation is the ultimate system for removing tobacco smoke from the breathing zone of people. And it can be very good, provided that the ventilation airflow rate per person is sufficiently large (more than app. 20 l/s per person). In this case the airflow pattern and contaminant concentrations may be as shown on the left side of Figure 3. However, often we end up with less airflow rates than 20 l/s per person. As pointed out above (Figure 3), contaminants like tobacco smoke may stratify in the inhalation level of people. This problem is treated in more detail by P.V. Nielsen (3). In this case, establishing different zones inside a room may be a better way to provide contaminant control. This can best be shown by an example, as below.

5 EXAMPLE: A RESTAURANT WITH TOBACCO SMOKING

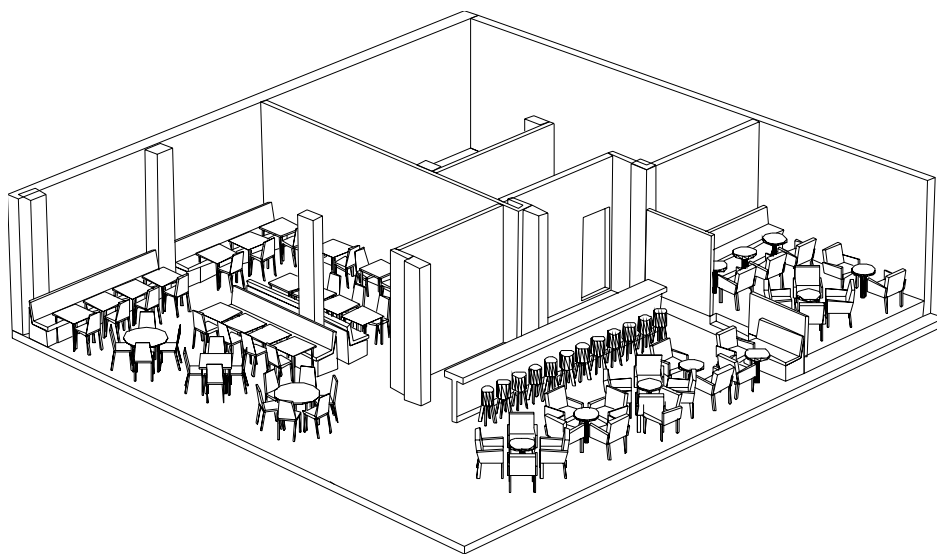

Figure 8 The restaurant to be ventilated.

The restaurant/bar shown in Figure 8, (“Kontoret Bar & Brasseri” in Trondheim, Norway), was to be ventilated so that non-smokers’ exposure to tobacco smoke were minimised. Room dimensions and occupancy were as follows:

Table 1 Room dimensions and occupancy for “Kontoret Bar & Brasseri”.

Room dimensions	
Height	3 m
Floor area	132 m ²
Room volume	396 m ³
Maximum number of people in the restaurant	
Smokers	75 persons
Non-smokers	85 persons
Employees	6 persons
Max occupancy	176 persons

A similar room was analysed in the Rehva Displacement Ventilation guidebook (1). For occupancy of 102 persons, a displacement ventilation arrangement was found, and an airflow rate of 10 l/s per person was utilised. There are strong arguments for utilising the low airflow rate per person for maximum occupancy; most of the time, the number of people is very much lower than the maximum.

However, if the number of people in the room is increased to 176, and we require an airflow rate of 20 l/s, we get a total airflow rate of 3520 l/s. We found that there was not sufficient space available along the walls for sufficient air supply. Furthermore, the air volume flow required for having the pollutants stratify above people’s heads (app. 20 l/s per person) was a much larger ventilation rate than we aimed at.

6 ZONING STRATEGY

Thus, we chose the principle of establishing different zones for non-smoking and smoking. The air supply is located in the non-smoking zone, and the extract in the smoking zone. An air curtain is installed between the two zones to stop tobacco smoke from penetrating into the non-smoking zone. See Figure 9. This had been investigated in laboratory by Skåret and Rydock in 1998-99 (4). The principle is shown in Figure 10.

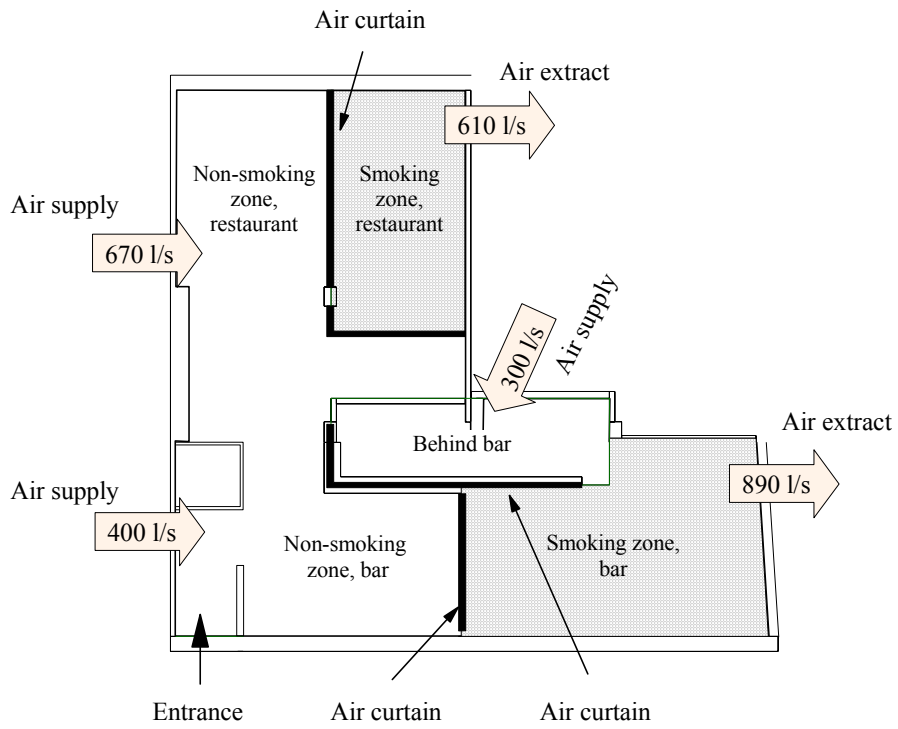

Figure 9 Location of zones and air curtains in the restaurant.

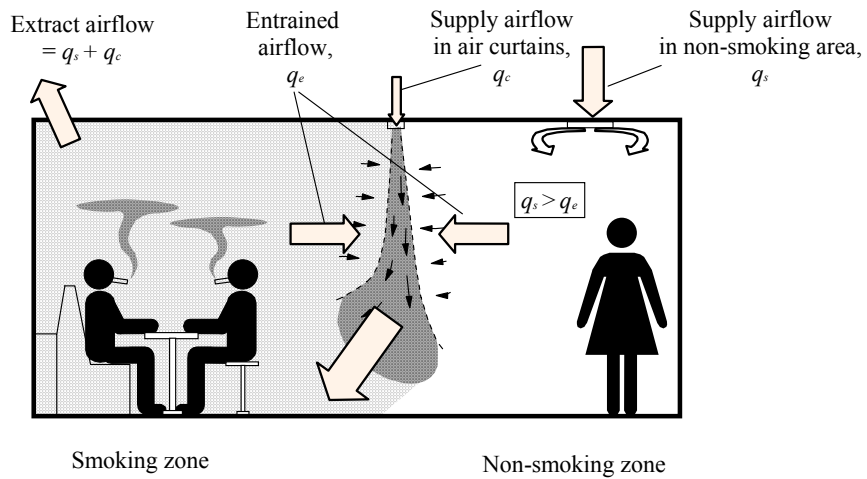

Figure 10 Ventilation zoning with air curtain.

7 AIR VOLUME FLOW DIMENSIONING

When applying air curtains, one has to ensure that the air entrained at one side of the air curtain is supplied from the clean side of the curtain. This is illustrated by the following example.

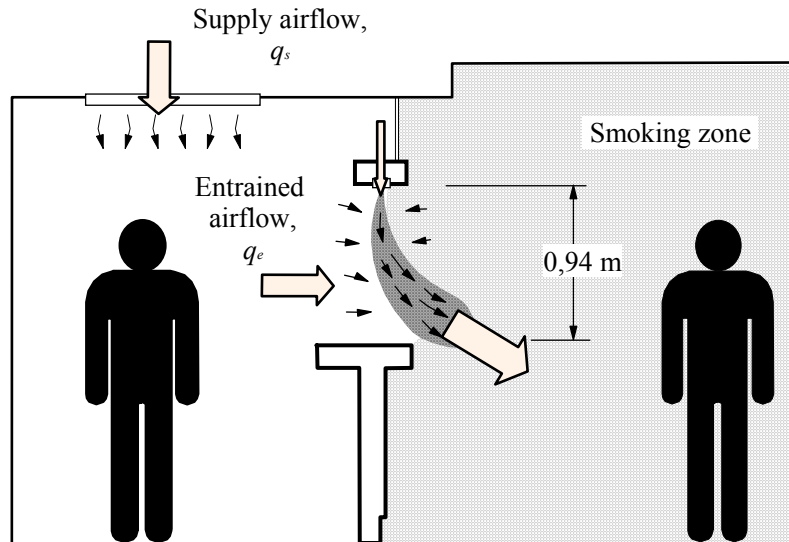

Figure 11 The ventilation air behind the bar is entrained in the air curtain.

Figure 11 shows a cross section of the zone behind the bar. To ensure that the air curtain flows outside the bar, as in Figure 11, the supply air flow inside the bar, q_s , must not be less than the airflow, q_e , entrained at the inner side of the air curtain. In this way, we ensure that smoke-contaminated air is not flowing into the area behind the bar.

The length of the air curtain along the bar is 7,5 metres. The airflow entrained on one side of the curtain is 29 l/s per metre length of the air curtain. Thus, the required air supply behind the bar is $q_{s\ bar} = 29\ \text{l/s m} \times 7,5\ \text{m} = 218\ \text{l/s}$. To allow for some air leakage in areas beside the air curtain, the supply airflow behind the bar is chosen to

$$q_{s\ bar} = 300\ \text{l/s}$$

By the same reasoning as for the bar, we find the airflow required to be supplied in the non-smoking zones of the restaurant. The resulting ventilation data are shown in the tables below.

Table 2 Ventilation data for “Kontoret Bar & Brasseri”.

Ventilation rates [l/s]	Supply	Diffusers	Air curtain	Extract
Restaurant	726	670	56	-610
Bar	427	400	27	-890
Behind bar desk	347	300	47	
Total	1500	1370	130	-1500

Table 7.3 Specific airflow rates.

Ventilation rate per unit floor area:		
Restaurant	18,2 l/s m ² =	65,3 m ³ /h m ²
Bar	13,4 l/s m ² =	48,3 m ³ /h m ²
Behind bar desk	22,4 l/s m ² =	80,6 m ³ /h m ²
Average	10,6 l/s m² =	38,2 m³/h m²

8 PRACTICAL EXPERIENCE

8.1 Airflow patterns

When testing the ventilation system after installation, we found several imperfections in the airflow patterns. The two most severe are shown in Figure 12. We are working on correcting these items, and installing more efficient air curtains.

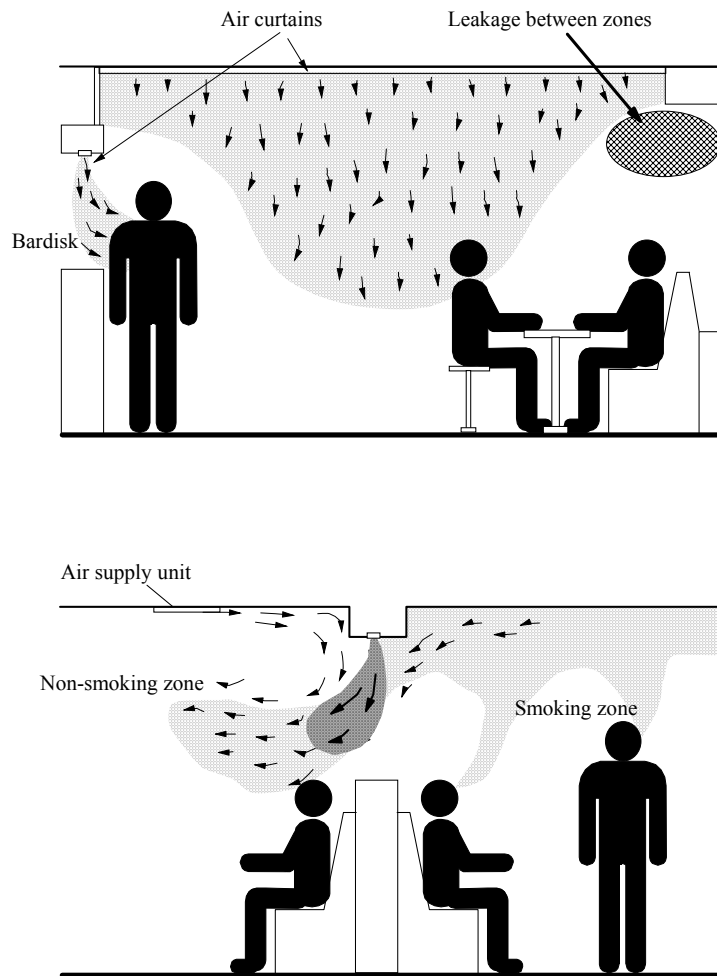

Figure 12 Airflow patterns found at the time of the nicotine measurements.

Zoning by air curtains has shown to give good separation between the zones. However, there are some conditions that have to be taken care of with this technique.

- The temperature of the supply air in the air curtain must not be warmer than the room air. Warm supply air may make the curtain ascend due to buoyancy. Preferably, the supply air should be slightly colder than the room air.
- Air curtains with low exit velocities are vulnerable to disturbing airflows. Air jets from diffusers will easily destroy the effect of the air curtain.

8.2 Air quality measurements

Results of nicotine measurements are shown in the figures below. Most of the measurements were made by two methods:

- the method of the national institute of public health (FH). This method uses passive sampling,
- the method of the university hospital in Trondheim (RiT). This method uses active sampling.

There are large deviations between the results of the two methods. We don't know what is right.

Nicotine concentrations in the bar

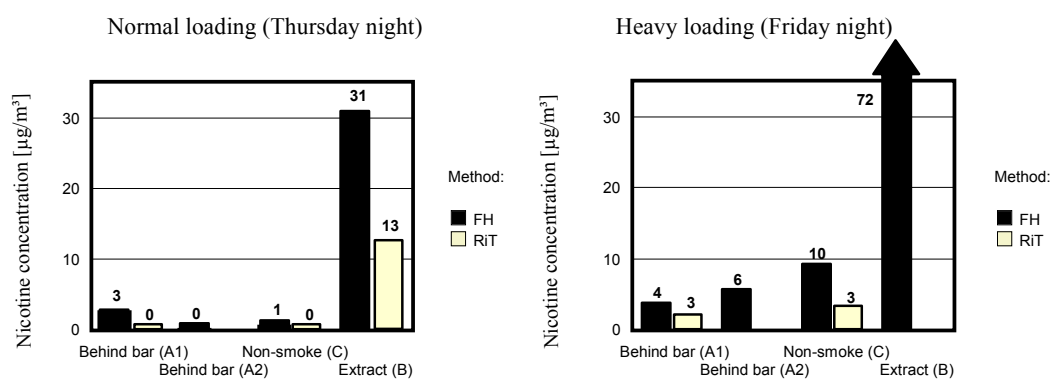

Figure 13 Nicotine concentrations measured in the bar area.

Nicotine concentrations in the restaurant

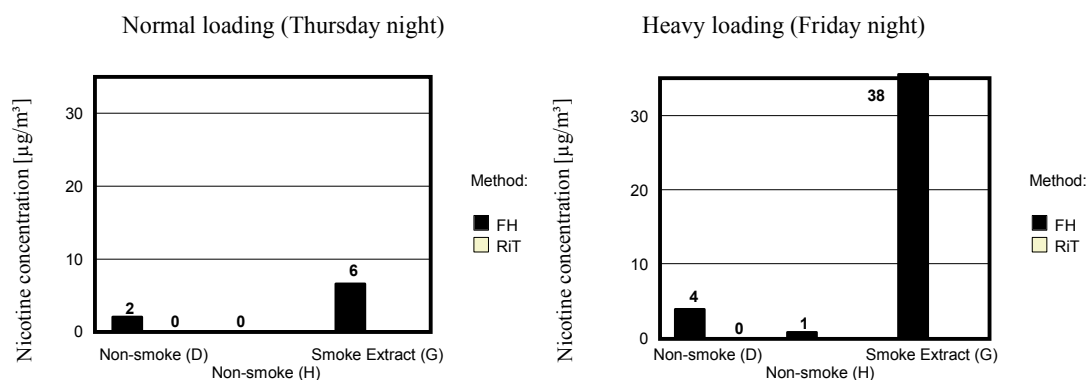

Figure 14 Nicotine concentrations measured in the restaurant area.

Staff exposure to nicotine

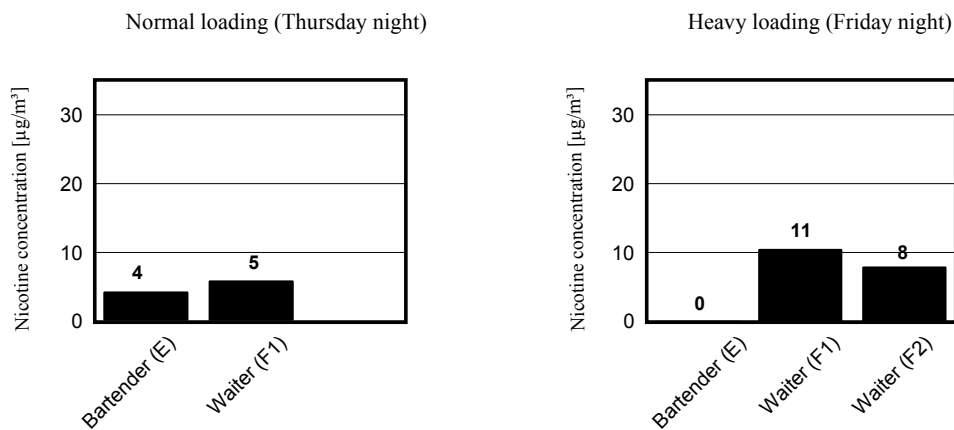

Figure 15 Staff exposure to nicotine in the air.

A more detailed description of this case study is given in (5). Mathiesen has made ventilation efficiency measurements in this restaurants, and concludes that both air exchange efficiencies and local ventilation indexes are far better than with mixing ventilation (6).

9 CONCLUSION

This paper points out two ways of establishing efficient airflow patterns in rooms that gives better air quality than mixing ventilation. Displacement ventilation is now well described by many authors, and the strong points and weak points are known. Zoning by low velocity air curtains has given promising results in prototype installations. However, this technique also requires that the designer is aware of the special airflow aspects related to air curtains.

10 REFERENCES

- (1) Skistad et.al.: "Displacement Ventilation in non-industrial premises" Rehva Guidebook #1. 2002. ISBN 82-594-2369-3.
- (2) Fitzner, K. Displacement ventilation and cooled ceilings, results of laboratory tests and practical installations Proc. Indoor Air 1996, Nagoya.
- (3) Bjørn, Erik and P.V. Nielsen: Dispersal Of Exhaled Air and Personal Exposure in Displacement Ventilated Rooms. Indoor Air 2001. ISSN 0905-6947

- (4) Skåret, E and Rydock, J. "Luftgardin som skilleprinsipp. ("Air curtains as a separating device") (Written in Norwegian). Norwegian Building research Institute, 1999
- (5) Skistad and Berner "Ventilation for tobacco smoking – a case study" Paper presented at "Roomvent 2002" in Copenhagen September 2002.
- (6) Mathisen, H.M. et .al.: "Ventilation efficiency in a restaurant for smokers and non-smokers" Paper presented at "Roomvent 2002" in Copenhagen September 2002.
- (7) Etheridge, D. and Sandberg, M. 1996. Building Ventilation - Theory and Measurement, Wiley.