

# Best practice guidelines for water management in aquatic leisure centres



Published by Sydney Water  
PO Box 399  
Parramatta NSW 2124

[sydneywater.com.au](http://sydneywater.com.au)

Copyright ©2011 Sydney Water Corporation

Sydney Water disclaims any liability for any inaccuracy or incompleteness in these best practice guidelines. Sydney Water makes no representation and does not warrant that any product, process or procedure referred to in this guide is suitable for any purpose. Persons using this guide are not relieved from the responsibility of relying on their own enquiries as to suitability of any information, product, process or procedure for any envisaged purpose.

## Message from the Managing Director

Businesses and industrial water users have made significant contributions to Sydney's long-term water sustainability. Over the past decade holistic water management practices have been widely adopted. Sydney Water recognises the importance of its business customers, and has been developing policies and products that focus on their needs.

These guidelines are one of a series of documents compiled by Sydney Water. They aim to capture the expertise of Sydney Water and some of its most efficient business partners to share 'best practice' industry knowledge.

Council owned aquatic centres in Sydney use around 1,000 megalitres (ML) of water each year. Three quarters of this is discharged to the sewers from water treatment systems, and from on-site kitchen, shower and toilet facilities. Adopting industry best practice to manage this water use and discharge can make a huge difference to the safe and efficient operation of any aquatic centre.

Between 2005 and 2010, aquatic centres in Sydney reduced their yearly potable water use by 150 ML. This led to a drop of around 113 ML in the volume of wastewater discharged to sewers and treatment plants over this period.

Improvements in backflow prevention and trade waste practices also helped protect the community and the environment.

This document summarises the most efficient operational procedures and management practices for aquatic centres. It has been put together to help council and aquatic centre sustainability officers, facility managers and swimming pool operational staff to share the benefits that come from improved water management.



**Kerry Schott**  
Managing Director, Sydney Water



**Kerry Schott**  
Managing Director

# Message from the Aquatic and Recreation Institute and Australian Leisure Facilities Association

Given the profile of swimming pools in the community, the aquatic and recreation industry is in a unique position to influence community attitudes and behaviour in the establishment of sustainable communities. This puts a community service obligation on us as an industry, not only to implement sustainable operational practices, but also to communicate to the community how these practices can be applied in the commercial and residential sector.

Since water is our core product, the industry is by definition a significant user of probably the community's most precious resource. As evidenced by the closure of a number of public pools during the recent drought, there is a business and social risk to our community facilities if no action is taken to mitigate inevitable water shortages in the future.

While many facilities have already made significant and encouraging improvements with up to 70% savings on water use, there is still much more work to be done in the industry as a whole.

Therefore, as the peak body representing aquatic and recreation facilities in NSW, the Aquatic and Recreation Institute with the Australian Leisure Facilities Association, are proud to support Sydney Water in developing and producing of the *Best practice guidelines for water management in aquatic leisure centres*.

We trust you will find these guidelines a practical and informative tool to implement significant water savings in your own facilities. These may be small operational changes or significant improvements, such as water harvesting. No matter how small the improvement it is worth remembering that 'every drop counts'.



**Nicde Murphy Pachdeek**  
President Aquatic and  
Recreation Institute



**Gary Penfold**  
Chair Australian Leisure  
Facilities Association



# Acknowledgements

Sydney Water thanks the following organisations for their help in developing the *Best practice guidelines for water management in aquatic leisure centres*:

- Australian Leisure Facilities Association
- Aquatic and Recreation Institute
- NSW Department of Health
- National Project Consultants Pty Ltd
- ECC Pty Ltd

Specific individuals contributed to and gave critical and constructive review and help with the document:

- Sara Raishbrook – Sydney Water – Business Customer Services
- Robert Quinn – National Project Consultants Pty Ltd
- Wayne Dettmann – ECC Pty Ltd
- Sally Armstrong – Sydney Water – Business Customer Services
- Julie Bye – Sydney Water – Communications & Marketing
- Philip Halkyard – Sydney Water – Business Customer Services
- Christopher Letherbarrow – Sydney Water – Business Customer Services
- Fernando Ortega – Sydney Water – Business Customer Services
- Para Parameshwaran – Sydney Water – Business Customer Services
- Neil Shaw – NSW Department of Health

A panel of aquatic centre managers in NSW helped guide the development of the document and gave critical and constructive review:

- Gary Penfold – Warringah Council
- Anthony Burling – Gosford City Council
- Tatjana Domazet – Bankstown City Council
- Paul Hartman – Ryde Aquatic Leisure Centre
- Reece Heddle – Randwick City Council
- Peter Shields – Fairfield City Council
- Annette Sillan – Sutherland Shire Council

Sydney Water would also like to thank all the aquatic centres who agreed to be case studies and centres and companies that provided photographs:

- Andrew Boy Charlton Pool, City of Sydney Council
- Canterbury Pool, Canterbury City Council
- Des Renford Aquatic Centre, Randwick City Council
- Ian Coombes Australia Pty Ltd
- Ian Thorpe Aquatic Centre, City of Sydney Council
- Springwood Aquatic Centre, Blue Mountains City Council
- Warringah Aquatic Centre, Warringah Council
- Jesse Taylor Photography

# Contents

Message from the Managing Director

Message from the Aquatic and Recreation Institute  
and Australian Leisure Facilities Association

Acknowledgements

Contents	4
List of figures	6
List of tables	7

## **Part 1**      **Understanding and managing your water use**      **8**

Chapter 1	Water use in aquatic centres	10
Chapter 2	Aquatic centre KPIs and targets	12
Chapter 3	The link between water and energy	14
Chapter 4	The true cost of water	16
Chapter 5	Management tools	20
Chapter 6	Monitoring water use	23
Chapter 7	Water efficiency audits	30
Chapter 8	Water balance	33
Chapter 9	Action plans	34
Chapter 10	Managing staff and contractors	35
Chapter 11	Justifying water efficiency projects	36
Chapter 12	Sustainability and funding opportunities	37

## **Part 2**      **Leaks and swimming pool operation**      **38**

Chapter 13	Leaks and base flows	41
Chapter 14	Saving water from treatment	50
Chapter 15	Saving water in filtration and make-up systems	56
Chapter 16	Evaporation	68

## **Part 3**      **Aquatic centre efficiency**      **72**

Chapter 17	Amenities	75
Chapter 18	Kitchens and kiosks	87
Chapter 19	Cleaning your aquatic centre	89
Chapter 20	Water features	90
Chapter 21	Gardens and sports fields	92
Chapter 22	New and renovated aquatic centres	96

<b>Part 4</b>	<b>Alternative water sources</b>	<b>98</b>
Chapter 23	Rainwater	101
Chapter 24	Wastewater	105
Chapter 25	Groundwater	110
<b>Part 5</b>	<b>Managing your wastewater</b>	<b>112</b>
Chapter 26	Sewerage Usage Discharge Factor	114
Chapter 27	Volume measurement	115
Chapter 28	Trade waste	116
Chapter 29	Trade waste in aquatic centres	117
Chapter 30	Backflow prevention	120
<b>Appendix 1</b>	<b>Risk management for using alternative water sources</b>	<b>122</b>
Chapter 31	Factors affecting microbial risk	125
Chapter 32	Managing risks of using alternative sources of water	130
Chapter 33	Risk matrixes for different types of pools	137
<b>Appendix 2</b>	<b>Water saving checklist</b>	<b>146</b>
<b>Glossary</b>		<b>154</b>

## List of figures

<b>Figure 1</b>	– Water use in council aquatic centres in Sydney	10
<b>Figure 2</b>	– Water use breakdown of a typical aquatic centre	14
<b>Figure 3</b>	– Energy use breakdown of a typical aquatic centre	14
<b>Figure 4</b>	– Some additional costs of water in aquatic centres	16
<b>Figure 5</b>	– Water use charges (\$/kL) from 1997 to 2012	17
<b>Figure 6</b>	– How to read a simple water meter	24
<b>Figure 7</b>	– How to read a larger water meter	24
<b>Figure 8</b>	– A graph of typical water use information from a data logger	26
<b>Figure 9</b>	– Aquatic centre hydraulic diagram	33
<b>Figure 10</b>	– Water use breakdown of a typical aquatic centre	40
<b>Figure 11</b>	– Energy use breakdown of a typical aquatic centre	40
<b>Figure 12</b>	– Site water use monitoring profile indicating a base flow	41
<b>Figure 13</b>	– Circulation system of a typical commercial pool	42
<b>Figure 14</b>	– The daily cost of a water leak based on water and wastewater use charges (2010–11)	46
<b>Figure 15</b>	– Pressure filter	57
<b>Figure 16</b>	– Pre-coat filter	58
<b>Figure 17</b>	– Water use breakdown of a typical aquatic centre	74
<b>Figure 18</b>	– Breakdown of water use in amenities	75
<b>Figure 19</b>	– Options for water efficiency projects	100
<b>Figure 20</b>	– Magnetic flow meter	115
<b>Figure 21</b>	– Key features of a typical backwash water holding tank	119
<b>Figure 22</b>	– Backflow explained	120
<b>Figure 23</b>	– Factors affecting microbial risk in aquatic centres	125
<b>Figure 24</b>	– Microbial risk for various swimming pool types	126
<b>Figure 25</b>	– Microbial risk for various swimming patron types	127
<b>Figure 26</b>	– Considerations for assessing microbial risk for various pool make-up water sources	128
<b>Figure 27</b>	– General hierarchy of microbial risk in pools, based on pool type, pool design and equipment, and pool users	129
<b>Figure 28</b>	– Procedure for recovering pool backwash water	133
<b>Figure 29</b>	– Deciding how to use treated backwash water	134

## List of tables

<b>Table 1</b>	– Aquatic centre KPIs using bather numbers	12
<b>Table 2</b>	– Aquatic centre KPIs using patron numbers	12
<b>Table 3</b>	– Checklist for water efficiency audits	30
<b>Table 4</b>	– Checklist for managing leaks	48
<b>Table 5</b>	– Water treatment comparison table	54
<b>Table 6</b>	– Water filter comparison table	60
<b>Table 7</b>	– Water media comparison table	63
<b>Table 8</b>	– Recommended pool temperatures for a range of pool activities	68
<b>Table 9</b>	– Advantages and disadvantages of pool cover types	70
<b>Table 10</b>	– WELS ratings for showers	84
<b>Table 11</b>	– WELS ratings for tapware	84
<b>Table 12</b>	– WELS ratings for toilets	85
<b>Table 13</b>	– WELS ratings for urinals	85
<b>Table 14</b>	– Water use for a range of water feature types	91
<b>Table 15</b>	– Risk management protocol for use of recycled water	107
<b>Table 16</b>	– Potential risk for re-use of recycled backwash water in various applications	131
<b>Table 17</b>	– Microbial risk of backwash water for bathers	131



# Part 1

## Understanding and managing your water use

Part 1 of the ***Best practice guidelines for water management in aquatic leisure centres*** is aimed at council and aquatic centre sustainability officers and facility managers. It presents benchmarks for water and energy use in aquatic centres and information to help you manage your water better.

## Chapter 1

# Water use in aquatic centres

In Australia, aquatic centres are major community facilities that require a large amount of water and energy to operate. There are around 1,900 aquatic leisure centres operating around Australia. Most of these are owned by local councils and managed either by councils or an external management organisation. Australian Leisure Facilities Association (ALFA) estimates yearly revenues of aquatic centres to be more than \$1.3 billion, employing over 50,000 staff.

Aquatic centres include all swimming pool facilities and aquatic leisure centres available to the public. They include any indoor or outdoor recreational pools, lap swimming pools, diving pools, hydrotherapy pools, family and toddler pools. Some aquatic centres

also have fitness facilities or equipment, such as basketball courts or gyms.

Aquatic centres are popular with the community, attracting around 263 million visits a year (the Aquatic and Recreation Institute). On average, every Australian visits a public pool once a month. As well as improving physical health and wellbeing, leisure facilities provide communities with a place to interact. This can improve mental wellbeing, particularly in isolated and disadvantaged communities.

In the Sydney region, there are many aquatic centres and swimming pools available to the public. These include:

- 84 council owned aquatic centres
- 57 swimming pools in clubs.

As well as these pools, there are many privately owned and operated pools available to the public in:

- fitness centres
- universities
- swimming schools
- hotels
- schools.

Aquatic centres owned and operated by councils in Sydney use around 1,000 megalitres (ML) of water a year. Around three quarters of this is discharged to the wastewater system from water treatment systems, and from on-site kitchens, showers and toilet facilities.

Figure 1 shows total water use in aquatic centres from 2005-06 to 2009-10. Sydney Water has worked with councils to help them better manage water use in aquatic centres. Between 2005-06 and 2009-10, aquatic centres in Sydney saved over 150 ML or about 15% of their water use. This reduced the volume of wastewater discharged to the wastewater system and treatment plants to about 113 ML, during the same period.

During this time, aquatic centres in Sydney improved their water efficiency by:

- improving water management practices
- monitoring water use

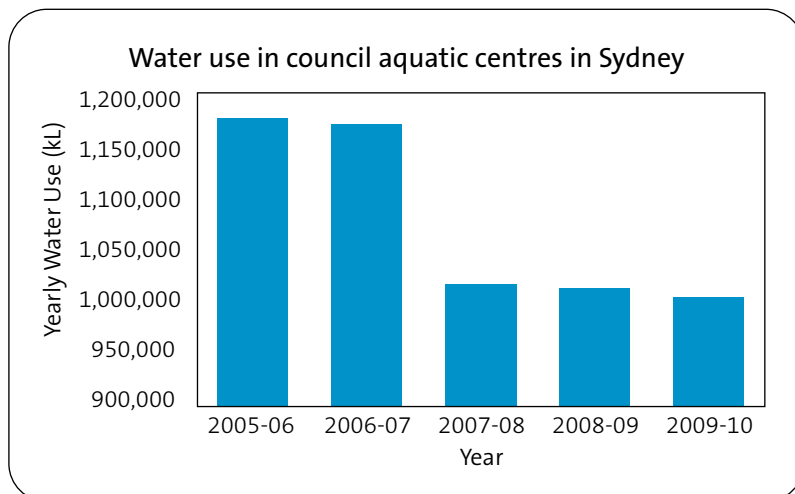

Figure 1 – Sydney aquatic centres have saved about 15% of their water use since 2005-06

- detecting and fixing leaks
- retrofitting existing amenities with efficient fixtures
- investing in alternative sources of water.

By reducing water use, implementing backflow prevention and improving trade wastewater discharge practices, aquatic centres

also saved money and helped protect the environment.

There is more to being sustainable than just saving water. Aquatic centre managers must understand their water and energy use and wastewater. They must also understand their Key Performance Indicators (KPIs), benchmarks and targets.

This guide provides practical steps to assist councils, pool managers and operators to better manage their aquatic centres. It will help you to achieve efficiency and save money.



On average, every Australian visits a public pool once a month

## Chapter 2

# Aquatic centre KPIs and targets

Sydney Water completed a survey of 42 aquatic centres in Sydney to further understand their water use trends and practices. KPIs for each site were calculated where accurate patron and water use data could be obtained.

The data showed that water use per patron was generally lower in mixed-use aquatic centres incorporating sports facilities. This supports findings from previous water and energy audits, which show fitness and sporting facility patrons use little water, compared to what is needed for each swimming pool patron to support the pool functions.

Two sets of KPIs were developed to reflect the differences between these types of centres. The first set of KPIs (Table 1) is for single use aquatic centres where all patrons are swimming patrons (bathers) or for mixed-use centres that record bather numbers separately from other patrons.

**Table 1 – Aquatic centre KPIs using bather numbers**

Rating	KPI
Best practice	<20 L/bather
Good	20-40 L/bather
Fair	40-60 L/bather
Poor	>60 L/bather

Mixed-use centres where bather numbers are not recorded separately have a lower KPI to reflect the lower water use of non-swimming patrons. KPIs for mixed-use centres are in Table 2.

**Table 2 – Aquatic centre KPIs using patron numbers**

Rating	KPI
Best practice	<10 L/patron
Good	10-25 L/patron
Fair	25-40 L/patron
Poor	>40 L/patron

In 2008, Sydney Water identified energy use KPI's from ten water and energy audits carried out at aquatic centres in Sydney. Aquatic centres that performed the best were using less than:

- 20 MJ/patron
- 2 GJ/m<sup>2</sup> heated pool area/year.



## Chapter 3

## The link between water and energy

The cost of energy (gas and electricity) and water will continue to rise. Aquatic centre managers and pool operators must understand the link between energy and water. By using water efficiently, energy savings can also be made, saving a lot of money.

**‘Many energy and water saving measures are interdependent. Given the relative high cost of energy, this usually makes such conservation measures a compelling investment.’**

Robert Quinn, National Project Consultants.

### Water and energy use

Sydney Water conducted detailed water and energy audits of ten aquatic centres in the Sydney metropolitan area. Figures 2 and 3 below show the typical breakdown of water and energy use at these centres.

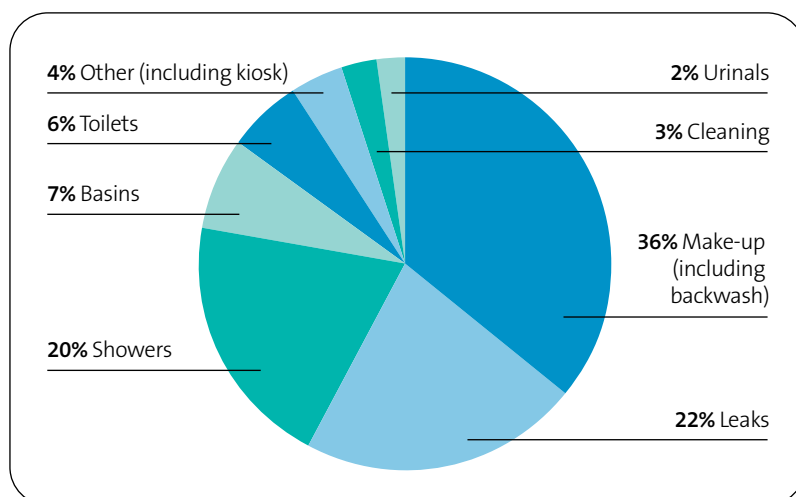

Figure 2 – Water use breakdown of a typical aquatic centre

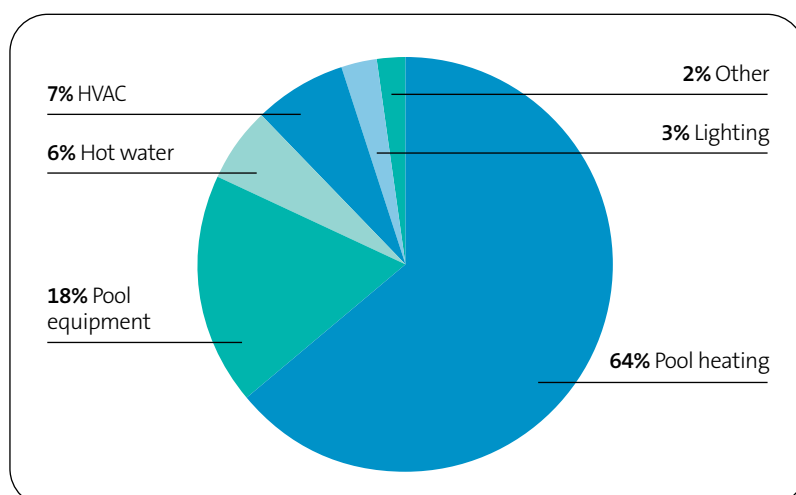

Figure 3 – Energy use breakdown of a typical aquatic centre

Energy use is directly related to water use when used for:

- pool heating (64%)
- pool equipment (18%)
- hot water systems (6%).

Indirectly, the pool hall heating and ventilation system affects water use through evaporation, so optimising these systems can save valuable water and energy.

By focusing on the following areas, the easiest savings can be made:

- Locating and fixing leaks
- Optimising filter backwash procedures
- Managing pool water quality
- Reducing evaporative loss

- Reducing water use in:
  - amenities
  - kitchens and kiosks
  - water features
  - landscaped areas
  - cleaning practices.

These areas are discussed in parts two and three of these guidelines.



By using water efficiently in aquatic centres, energy savings can also be made

## Chapter 4

# The true cost of water

The real cost of water to a business is more than the water meter charges. If you use less water, you directly pay less in water, wastewater and trade wastewater charges. Indirectly, you use less energy to pump and heat water and chemicals to treat the water. This allows you to save energy and chemicals.

The audits done of Sydney aquatic centres in 2008, showed pool water can cost between \$7 and \$11 a kilolitre (2006-07 pricing), once other costs are taken into account. Figure 4 shows the additional aspects of water use that may affect the cost to a business in an aquatic centre. Additional charges related to water use in pools depend on the specific heating and pumping equipment used, the type of energy used to power

equipment and the specific chemical regime of the pool. These additional charges are for:

- energy use
- chemical use.

In addition to water and wastewater charges, energy is used to pump and heat pool water, and chemicals are used to treat the water. Losses of water from the pool, due to leaks or inefficient practices, can incur extra costs to the business. By including energy and chemical treatment costs in your calculations, you can assess more accurately the true cost of your pool water.

By carefully calculating the true cost of your water, you can use cost savings associated with saving water to accurately calculate payback periods.

## Water charges

Sydney Water applies the following charges to customers connected to the water supply:

- Service charges
- Water use charges
- Wastewater use charges
- Trade wastewater charges

For the latest charges visit [sydneywater.com.au](http://sydneywater.com.au)

## Service charges

These include meter service charges for your drinking water or wastewater system connection.

Water and wastewater service charges are based on the size of your water meter. If you reduce water use, investigate resizing your meter to reduce water and wastewater charges.

If you are planning to connect to alternative water sources like recycled water or sewer mining, look at reducing the size of your water meter. However, you should consider any future plans for additional buildings or extensions that might increase water use.

If you need to resize your meter, call Sydney Water on 13 20 92 or consult your Business Customer Services representative.

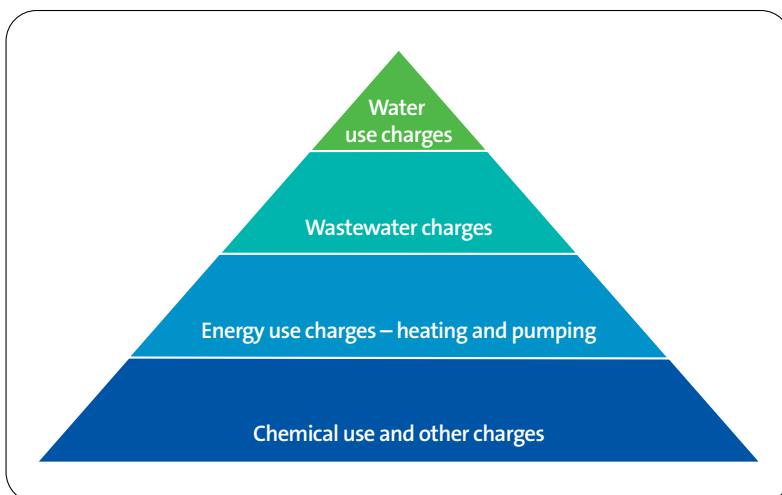

Figure 4 – The real cost of water to aquatic centres is more than water use charges

## Water use charges

These include charges for the amount of drinking water you use. The cost of water has almost doubled over the last five years (Figure 5).

Sydney Water charges customers \$2.012 for every kilolitre (kL) of water used (2010-11). Water prices will continue to rise. The Independent Pricing and Regulatory Tribunal (IPART) has approved price rises for Sydney Water until 2011-12.

## Wastewater use charges

This includes charges for being connected to the wastewater system. Wastewater (Sewerage) use charges apply to all non-residential properties.

Businesses that discharge more than 500 kL of wastewater a year, or 1.37 kL a day, are charged \$1.45/kL

(2010–11 pricing) to reflect the costs of treating and managing wastewater.

Unless the volume of wastewater is directly metered, Sydney Water uses a sewerage usage discharge factor (SUDF) to calculate the amount of wastewater you dispose of to the wastewater system. The SUDF is the ratio of water going out of your business through the wastewater system, compared to water coming in from Sydney Water water mains. Your SUDF depends on your business type and the equipment you have installed.

The SUDF includes all discharge to the wastewater system including liquid trade waste and wastewater and, in some cases, first flush stormwater from open areas. SUDF is the ratio of the estimated volume discharged into the wastewater system to the total water used.

Most aquatic centres have a SUDF of 70–95%. This is based on the amount of water supplied that is eventually discharged to the sewer.

## Trade wastewater charges

Cafés and kitchens can discharge trade wastewater, including greasy or oily wastes. They may be required to have a grease arrestor and are charged a trade wastewater quality charge by Sydney Water to cover the extra costs of treating this wastewater. Visit [sydneywater.com.au](http://sydneywater.com.au) or call 13 20 92 to speak with a Business Customer Services representative about trade wastewater charges.

Submetering trade wastewater discharges enables you to better assess your trade wastewater amounts and may help you reduce your trade wastewater charges.

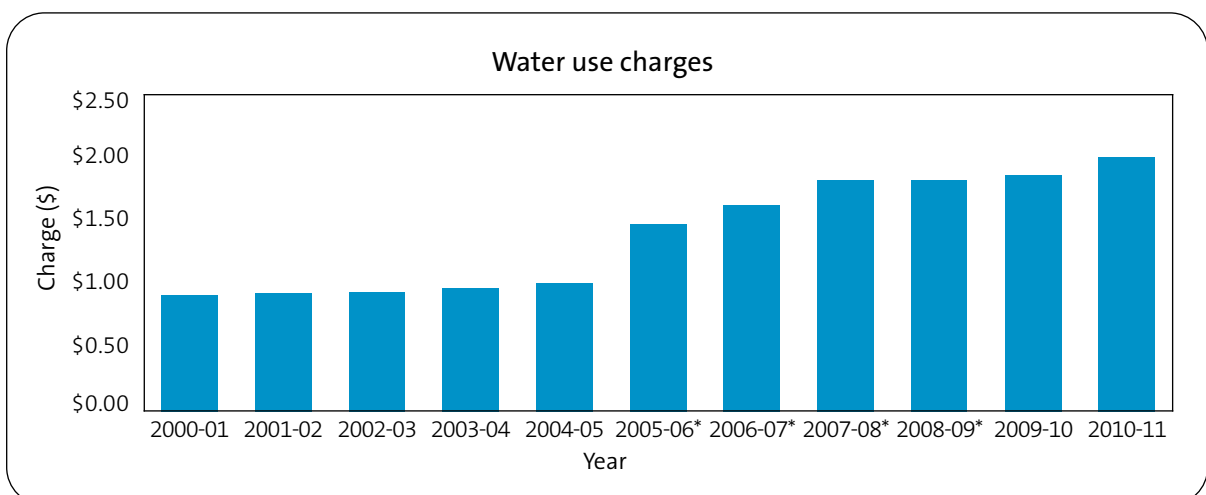

\*indicates tier 2 pricing (water use is greater than 1,096 litres each day)

Figure 5 – Water use charges (\$/kL) from 1997 to 2012. The cost of water has almost doubled over the past five years



Sydney Water's 'Wastesafe' system ensures grease arrestor waste from all customers with a trade waste agreement is safely collected, transported and disposed of. Grease arrestor contractors bill customers for collecting and transporting grease arrestor waste. Sydney Water bills customers directly when waste

is processed at a Wastesafe depot. Find a full list of water and wastewater charges at [sydneywater.com.au](http://sydneywater.com.au)

### Energy costs

A technical water and energy audit helps you identify what proportion of total water used at the centre is for pool make-up, and the electricity

and gas costs associated with pool equipment and heating swimming pool water. After you have determined the yearly costs of electricity and gas, divide it by the number of kilolitres used in the pool make-up each year. This figure is your energy cost for each kilolitre of pool water.

By working out how much electricity and gas you use, you can calculate the CO<sub>2</sub> emissions associated with each, and the overall CO<sub>2</sub> emissions. Including emission reductions in a business case for water efficiency helps support the proposal.

As a general rule, the greenhouse gas emissions from electricity and natural gas are:

- natural gas (NSW direct source emission factor) – 51.7 kg GHG/GJ
- electricity (NSW full fuel cycle emission factor) – 0.985 kg GHG/kWh = 273.6 kg GHG/GJ

### Chemical treatment and maintenance costs

Calculate the cost of chemicals for treating pool water and the cost of maintaining pool equipment during the year. After you determine the yearly costs of chemical treatment and maintenance, divide it by the number of kilolitres used in pool make-up each year. This figure is your chemical and maintenance cost for each kilolitre of pool water.

## Case study

### Calculating water, wastewater usage and trade waste charges

An aquatic centre with a 50 mm water meter using 60 kL of water a day has a calculated SUDF of 90%. Its café serves hot food and is subject to a trade waste quality charge of \$1.23/kL. The café discharges 2.5 kL a day through the grease arrestor (volume 700 L) that is pumped out quarterly.

#### Water charges

Water cost 60 kL x \$2.012/kL

= \$120.72 a day or \$44,062.80 a year

Wastewater charge ((60 kL – 1.37 kL) x .90) x \$1.45

= \$79.57 a day or \$29,041.67 a year

Water service charge (based on 50 mm meter size) of \$195.70 a quarter or \$782.80 a year.

Wastewater service charge (based on 50 mm meter size x SUDF) of \$808.14 a quarter or \$3,232.56 a year

**Total = \$77,119.83 a year**

#### Trade waste charges

Trade waste quality charge 2.5 kL x \$0.624

= \$1.56 a day or \$569.40 a year

Wastesafe (grease arrestor) processing fee 700 L x 4 x \$0.136 = \$380.80 a year

Trade waste quarterly permit fee of \$20.24

= \$80.96 a year

**Total = \$1,031.16 a year**

**Total water and trade waste charges**

**= \$78,150.99 a year or \$3.57/kL**

Image left – By including energy and chemical costs and wastewater charges, you can more accurately assess the true cost of your pool water

## Chapter 5

# Management tools

Managing water efficiently means there are processes in place, which continually improve. This includes having effective communication, keeping good records, ensuring staff are trained, engaged and accountable, and having processes in place to make good decisions. These affect the flexibility and efficiency of your business.

Sydney Water's business customer program shows improved water management is the key to sustainable water efficiency. Without effective water management, technical improvements can only deliver short-term gains in water efficiency.

### Water management assessment

To help companies achieve better long-term resource management, Sydney Water runs management assessment for business customers. A management assessment helps you better understand how to improve water and energy management in your business.

A management assessment is not an audit. It is a self-managed tool that provides you with actions to continually improve your resources management. It analyses qualitative or non-technical measures, which all businesses must address to manage water effectively.

Qualitative approaches to water management include:

- leading and demonstrating corporate commitment
- understanding water use performance and savings opportunities
- using water use targets and KPIs to measure performance
- making people responsible and accountable for water management
- improving operations and maintenance practices
- managing supply and legal compliance
- incorporating the true cost of water into financial management practices
- using technology to drive innovation
- measuring, verifying and reporting regularly.

Our experience shows that the businesses that perform best in this assessment process are able to sustain water savings over the long term.

## The 7-point plan for holistic water management

The Sydney Water 7-point plan provides a useful framework for aquatic centres to develop a resource management plan to structure and prioritise their water management.

### 1. Seek commitment and leadership from senior management

Your council general manager or aquatic centre manager must commit to achieving sustainable and efficient use of water and energy, in writing.

Commitment and leadership from senior management is essential to ensure a successful water management program. To achieve real results, managers must take the lead in water efficiency and set an example for their staff.

Managers must encourage changes in business processes and behaviours to achieve sustainable water savings. A good example is to ask purchasing officers or staff to consider all costs over the life of equipment before buying. When taking into account maintenance, water and energy costs over the life of the item, the lowest priced unit may not always be the cheapest.

### 2. Appoint a water manager

The aquatic centre manager is the best champion to drive efficiency in your aquatic centre. They are responsible for managing budgets and achieving savings.

Organisations that appoint a person to manage water achieve the best results. The person must have dedicated responsibility for water management, although this does not need to be their only task.

Make sure your council's sustainability officer engages with the aquatic centre water manager to share plans and objectives of any projects.

### 3. Understand how you manage water and energy

Conduct your own water audit (Chapter 7) or contact Sydney Water's Business Customer Services team for assistance.

Determine where, how and when water is used in your aquatic centre. Audit water use and develop a total water balance for your site. Include all water entering and leaving the site, including wastewater and evaporation.

Complete a fixtures and equipment survey so you know exactly what equipment you have and how much water it uses. This will help you identify inefficient equipment and opportunities to save, and to quantify the additional costs of water, including energy and chemical treatment costs.



Some of the simplest ideas for saving water are often the most cost effective

#### 4. Identify opportunities to improve water efficiency

Some of the simplest ideas for saving water are often the most cost-effective, so don't be afraid to think laterally. Water efficiency is not just about large-scale technical solutions. Small changes can make a big difference. Ensure all staff have the opportunity to contribute water saving ideas.

#### 5. Set a realistic goal

It is important to have realistic efficiency targets so everyone can measure the gains. Aquatic centres that conduct a water audit can typically set savings targets of 20% or more. Benchmark against KPIs such as litres for each bather or patron. (See Chapter 2 for more information about KPIs in aquatic centres.)

#### 6. Develop a water efficiency strategy

A water efficiency strategy should work through the following principles in order:

##### Avoid

Avoid using water where possible. Repairing leaks is the most cost effective way to minimise water use. Retrofitting or upgrading amenities or pool filters also avoids unnecessary water use.

##### Reduce

Where water use can't be avoided, reduce the amount being used. Reduce the flow through taps and add spray nozzles to the end of hoses. Replace inefficient amenities with new, efficient models.

##### Re-use

If you cannot reduce the amount of water being used, try to use it more than once. Some aquatic centres treat and re-use filter backwash water for pool make-up or irrigation.

##### Recycle

Recycling water is an alternative where health guidelines allow. For example, treated recycled water cannot be used in swimming pools, but may be used for irrigation or toilet flushing.

When you consider a water efficiency strategy, assess the impact of water efficiency on energy use and trade waste compliance (see Part 1 Chapter 4 and Part 5).

#### 7. Involve staff and customers

Behavioural change of staff and customers will ensure water savings are maintained. Include water and energy management practices in your staff inductions and training to clearly identify their roles and responsibilities. Highlight achievements and savings.

Think of innovative ways to engage staff and customers in water efficiency. Ensure they can offer ideas and take part in water efficiency initiatives to increase their impact. Increase staff and customer water efficiency awareness and understanding through management reporting, posters on bulletin boards, and newsletters.

Competitions can also be a good way to increase awareness. Consider engaging your customers, or making use of national events such as National Water Week ([www.nationalwaterweek.org.au](http://www.nationalwaterweek.org.au)) to promote water efficiency.

## Chapter 6

# Monitoring water use

Monitoring your water and energy use regularly is the key to maintaining an efficient aquatic centre. It is impossible to save water if you don't know how much you are using, and where and when it is being used. Monitoring water use helps you understand your water use patterns and identify leaks that could otherwise remain undetected, costing you unnecessary water, energy and wastewater charges.

There are four main ways you can monitor your water use:

1. Manual meter reading
2. Using Sydney Water's EDC Online
3. Using a monitoring system
4. Using your building management system (BMS).

To get more detailed information from your monitoring, you can install submeters on key water-using equipment.

### Manual meter reading

Sydney Water reads business water meters monthly or quarterly. However, it is better you read your own water meter, preferably daily as part of your routine maintenance program.

To check if your aquatic centre has leaks, read your meter at the close and start of the business day. If there is a difference between the two readings and there was

little or no activity overnight, you may have a leak. Leaking amenities and faulty float valves commonly cause overnight flow.

### How to read your meter

Most water meters have a series of numbers. The numbers measure the amount of water used in kilolitres and litres. The numbers in black measure kilolitres (thousands of litres) and the red numbers measure fractions of a kilolitre.



Read your water meter as part of your routine maintenance program

Standard water meters may have a series of six, seven or eight numbers. Examples of how to read these meters are given in Figure 6.

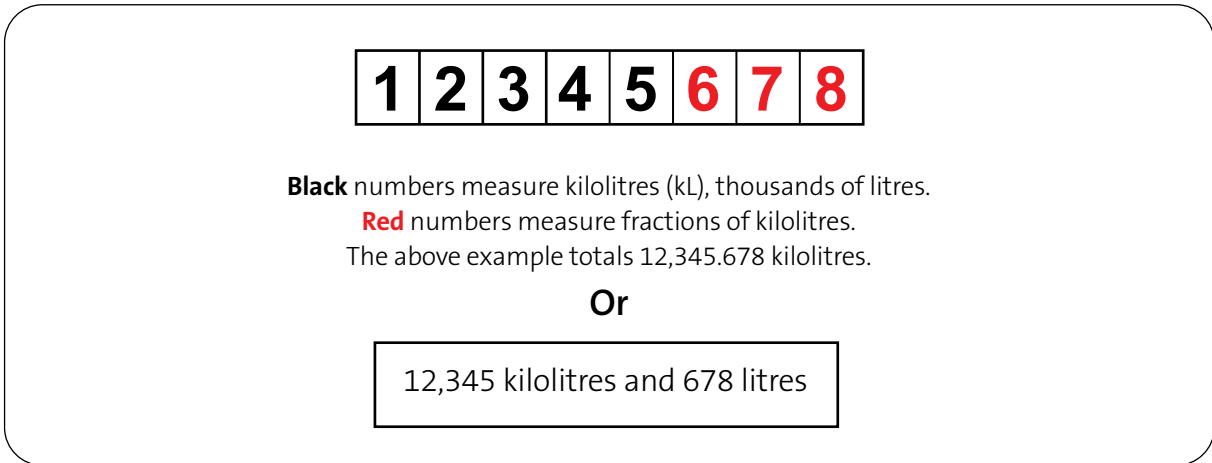

Figure 6 – How to read a standard water meter

Larger water meters may break down water use even further by using dials as well as a series of numbers. One example of how to read a larger water meter is shown in Figure 7. If your water meter is different and you are having trouble reading it, contact the meter manufacturer for detailed meter reading instructions.

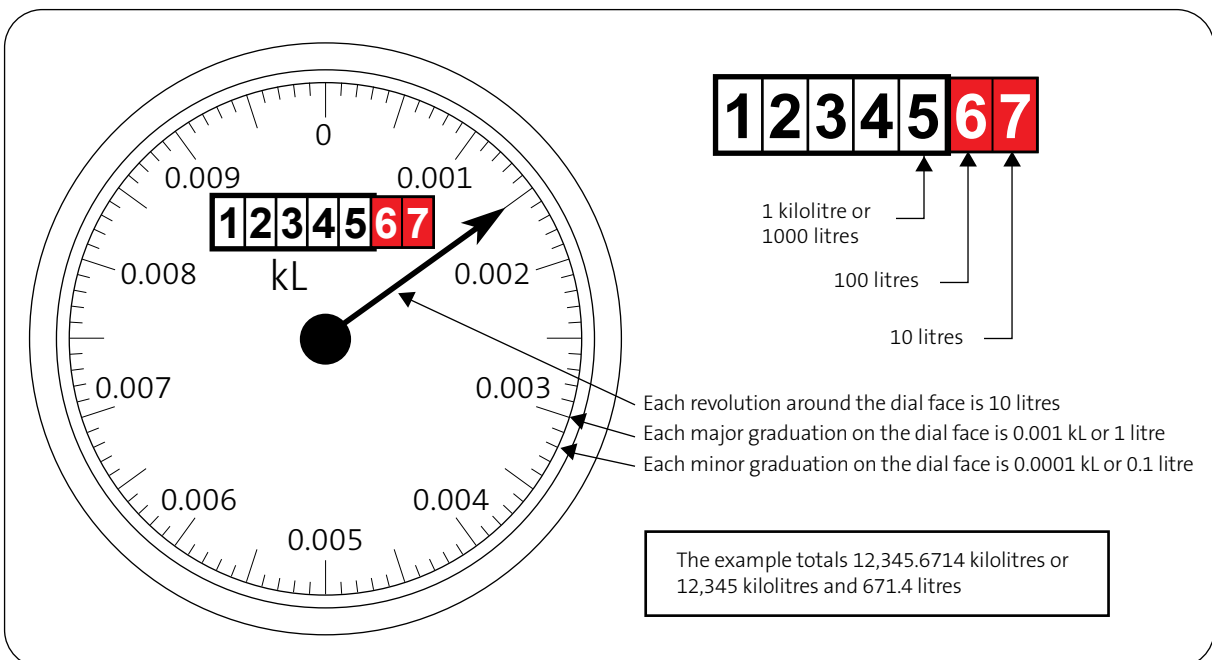

Figure 7 – How to read a larger water meter

## EDC Online

EDC (Every Drop Counts) Online is a secure website to help Sydney Water business customers track, report and organise their water information. It can help you:

- set priorities for water management
- track water use after projects have been implemented
- monitor water use
- set KPIs and targets.

### Key features include:

- up-to-date water use data for business customers (based on billing frequency)
- automated graphic reports to help you interpret trends in water use for all sites, each individual site and each billing meter
- ability to produce water use figures benchmarked against business specific KPIs
- access to meter reading data that can be downloaded for analysis
- a location for your important water management documents.

Register for EDC Online at [sydneywater.com.au](http://sydneywater.com.au)

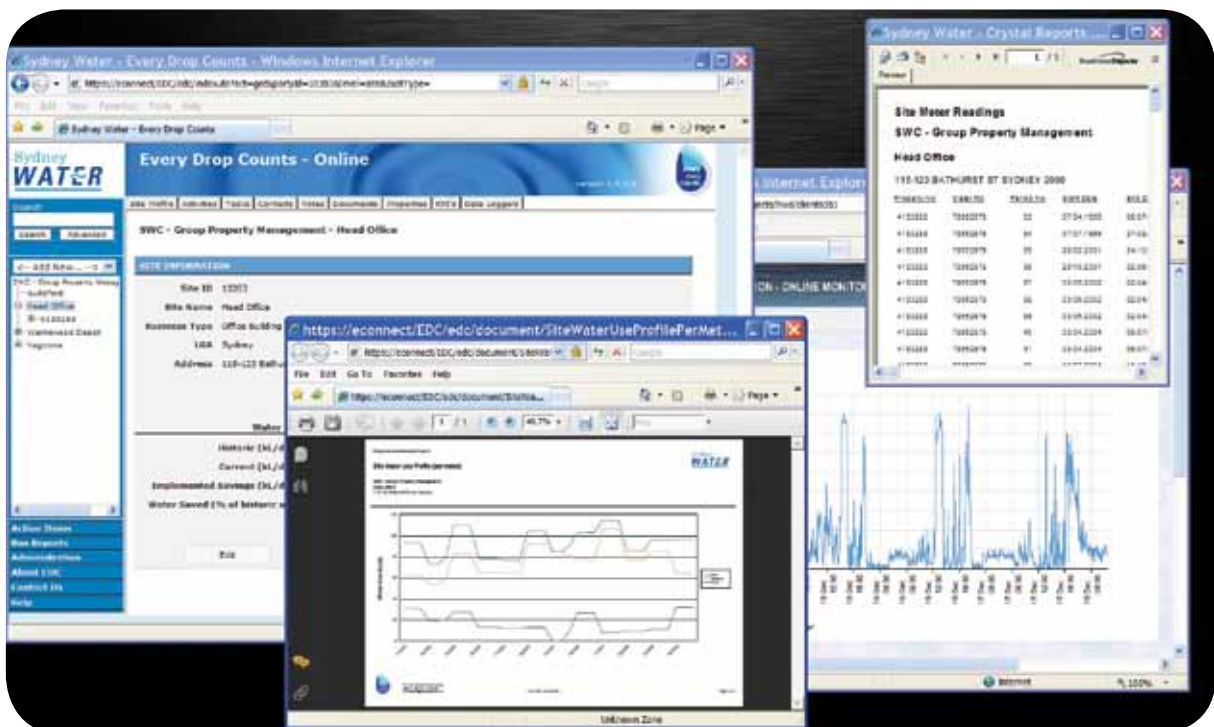

Customised EDC online water use reports. These automated graphic reports help you interpret water use trends

## Monitoring systems

Installing an automatic monitoring system is more efficient than manual meter reading for monitoring water use and can monitor multiple submeters. Data loggers fitted to your water meters can store and transmit information on water use. There are two types of monitoring systems – offline and online.

**Offline monitoring systems** are affordable, collect valuable data and are easy to use. They involve connecting a data logger to a water meter, which emits pulses. Pulse emitting water meters emit an electronic or magnetic pulse every time a set volume of water (1 litre, 10 litres) passes through it. The logger records the number of pulses in a given period (5-15 min). Water use is calculated from the number of pulses and the given pulse volume for a particular water meter.



Data loggers can be easily installed and used

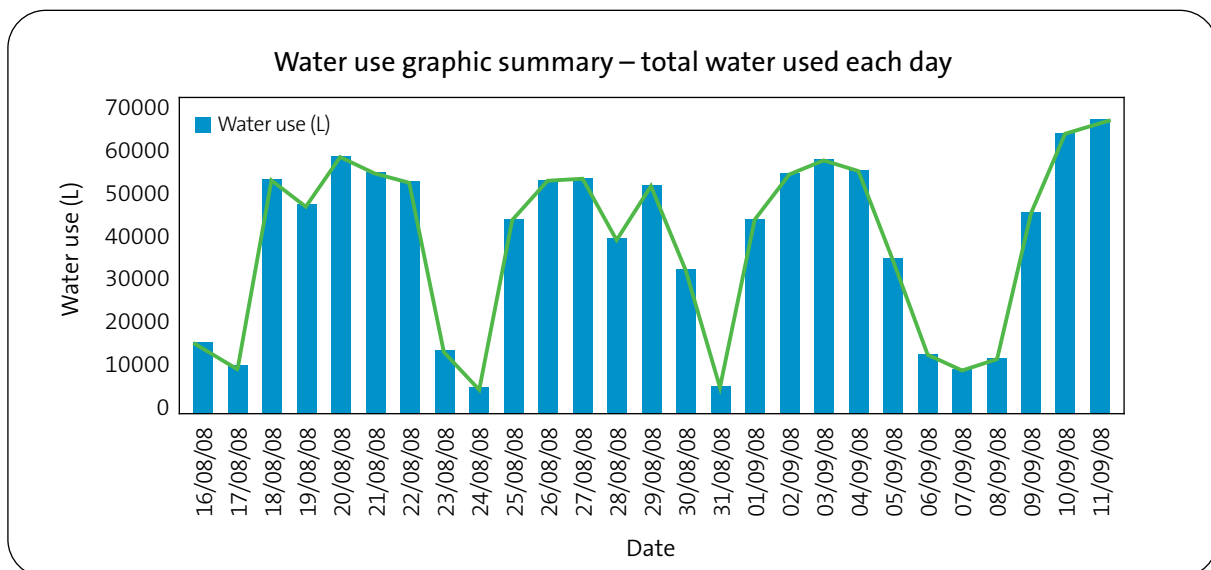

Figure 8 – A typical graph of water use information from a data logger

The data from the logger should be downloaded every 15 days and analysed. Check that the supplier of your data logger provides software and instructions to download and interpret the information. Data loggers can easily be installed and used.

**Online monitoring systems** can transmit water use data so it does not have to be downloaded. Like the offline data loggers, they can be installed on pulse emitting water meters and submeters. They operate similarly to the offline systems but transmit data to a website where it is automatically interpreted and displayed in real time. These systems provide alarms and SMS or email alerts if there are dramatic changes in water use or base flow indicating leaks.

To establish an online monitoring system for your aquatic centre, you pay an upfront cost to set up the

system, and a smaller yearly service charge. The cost increases with the number of submeters monitored and effectiveness of transmission.

The costs to install and operate continuous online monitoring are generally offset by savings in water and energy costs

through quick detection of leaks, provided they are repaired quickly. In aquatic centres these systems can help in water use reporting and can report KPIs and targets. Quality monitoring can also be linked to water monitoring to provide a holistic overview of centre performance.



By attaching a data transmitter to a water meter, you can send data to a website



By viewing your monitoring data online, you can see and interpret real time information

## Use your building management system

You can use your existing building management system (BMS) to continually monitor water use. Talk to your current BMS supplier about connecting water meters to your BMS. The cost to upgrade your system depends on the complexity of your hydraulics and centre layout.

Your BMS enables you to combine the monitoring of water, gas and electricity into a single system. This gives you a snapshot of current use, which you can compare to historical trends.

## Analyse water use information

Regularly monitoring your water use helps you manage water more efficiently. Graphing your water use data gives you a simple representation of how much water you are using and where you are using it. This makes it easier to identify patterns and changes. This means saving money by:

- spotting discrepancies in water use so you can quickly respond to leaks and equipment malfunctions
- collecting meaningful data on water use to justify water efficiency projects
- comparing energy and water use against KPIs for the centre or specific sections of the centre

- reducing energy and chemical use by preventing unnecessary water heating, pumping and treatment.

## Install submeters

To get the most out of your monitoring program, you must install and monitor submeters at key points in your centre. Submeters help you understand where and when water is being used. With this information, you can set the priorities for water efficiency actions.

You can prioritise submeters in your aquatic centre:

### Priority 1 – Swimming pools

Monitor the water added to pools to make-up for losses from leaks, splash-out, overflow and evaporation. This helps to detect leaks or faulty float valves that might be causing constant refilling of the pool. It also identifies unnecessary manual pool refilling by staff.

### Priority 2 – Amenities

Toilets, urinals and showers can use large amounts of water, depending on bather numbers. Monitoring amenities identifies leaks and measures the success of improved maintenance and cleaning procedures.

### Priority 3 – Outdoor areas

Monitor the water supply to your irrigation system and water features. They may not be a large part of your aquatic centre's water use, but outside leaks can be easily missed.

### Priority 4 – Kitchens and kiosks

Examining water use in kiosks helps you identify leaks and inefficient practices.



You can use your existing Building Management System to monitor water use by connecting your water meters

Image right – By tracking water use you can improve your performance



## Chapter 7

# Water efficiency audits

A water efficiency audit helps you determine priorities for water efficiency projects. This is vital information for any business case for water efficiency projects.

Key objectives of a water efficiency audit are to:

- identify water use patterns
- understand the water supply system
- identify deficiencies in the system, including leaks and waste

- identify water and energy efficiency opportunities, including water re-use
- develop water benchmarks and targets.

Business Customer Services offers subsidised water efficiency audits to business customers who use more than 80,000 litres a day. You can do a water efficiency check yourself or hire a consultant to do a more detailed study.

Follow the procedures in Table 3 to complete a comprehensive water efficiency audit of your centre.

**Table 3 – Checklist for water efficiency audits**

Audit stage	Procedures
<b>Planning and research</b>	<ul style="list-style-type: none"> <li>• Graph your historical water use. Is water use constant? Are there seasonal peaks? Can you explain any large peaks and troughs? If the graph is erratic, it may mean lots of leaks and poorly managed water use practices. What was the lowest monthly use and why?</li> <li>• Locate up-to-date hydraulic plans that identify water, wastewater and stormwater reticulation pipe networks.</li> <li>• List your water-using equipment. How old is the equipment and what is its expected water use? Do you have maintenance manuals? Is equipment being operated and maintained following the manufacturer's recommendations? Is more efficient equipment available?</li> <li>• Identify existing submeters and determine locations for new submeters.</li> <li>• Inspect access to the water pipe network, water services, existing meters, submeters and tanks. Can you inspect pipes? Can you read the meters easily?</li> <li>• Think about your water efficiency priorities. Do you want to save water to cut costs, boost community approval, improve facilities, or meet environmental standards?</li> </ul>

Audit stage	Procedures
<b>Collect and do</b>	<ul style="list-style-type: none"> <li>• If the centre is closed overnight, take meter readings to identify if there are flows when facilities are not being used.</li> <li>• Install logging equipment on meters and submeters.</li> <li>• Audit amenities and fixtures. Do flow tests to determine flow rates (use a bucket and a stop watch or a special flow cup) and identify inefficient water fixtures. What is the flow from taps and showers? How many single flush toilets do you have? Do you have cyclic flushing urinals? Are sensors for urinal flushes operating effectively? Do you notice any leaks?</li> <li>• Review infrastructure. What is the opportunity for rainwater re-use?</li> <li>• Is there an upcoming project where underground storage can be incorporated?</li> <li>• Do all downpipes feed to a few points so rainwater can be easily collected? Is stormwater collection an option? Are storage locations close to their point of use?</li> </ul>
<b>Review your operations</b>	<ul style="list-style-type: none"> <li>• Review cleaning and staff practices. Do staff use hoses or pressure equipment to wash down areas? Do kitchen staff turn off taps? Do cleaners report leaking equipment?</li> <li>• Review equipment that operates automatically. Ensure cooling and heating systems are not competing. Make sure your pool filter is running to specification. Refer to Part 2 for tips on how to do this.</li> <li>• Review water use outside the centre. Is vandalism a problem with taps being turned on? What are grounds staff and contractors' watering practices? How do they decide when to water?</li> <li>• Check water-using equipment to make sure it still operates efficiently. Measure the water issue of equipment to see if it still meets the manufacturer's specifications. How does it compare to best practice?</li> </ul>
<b>Calculate</b>	<ul style="list-style-type: none"> <li>• Develop benchmarks for water use and compare them to your targets or industry best practice.</li> <li>• Calculate how much water is costing for supply, discharge, treatment, pumping and heating.</li> <li>• Calculate hot water costs.</li> <li>• Calculate possible water savings and likely cost savings incorporating all costs.</li> </ul>
<b>Action plan</b>	<ul style="list-style-type: none"> <li>• Develop a 'water balance'. What uses the most water?</li> <li>• Identify your best water efficiency opportunities and prioritise them by simple payback or internal rate of return calculations.</li> <li>• Review water re-use or recycling opportunities.</li> </ul>



## Chapter 8

# Water balance

A water balance is a measure of how much water is entering and leaving your aquatic centre. Working out a water balance for your centre will also help you understand where water is being used.

Figure 9 is a hydraulic diagram of an aquatic centre. It shows where water is used in a centre. Once submeters

are installed, you can develop an accurate water balance.

Develop a water use balance using information from regularly monitored submeters. The best way to show water use is to draw a diagram of your water system. The diagram should include swimming pools, amenities, irrigation systems and kiosks,

as well as any water features.

Remember to include swimming pool water losses from evaporation and splash-out. Graph this information in a pie chart to show how much water is used in different parts of the centre and discharged to the wastewater system.

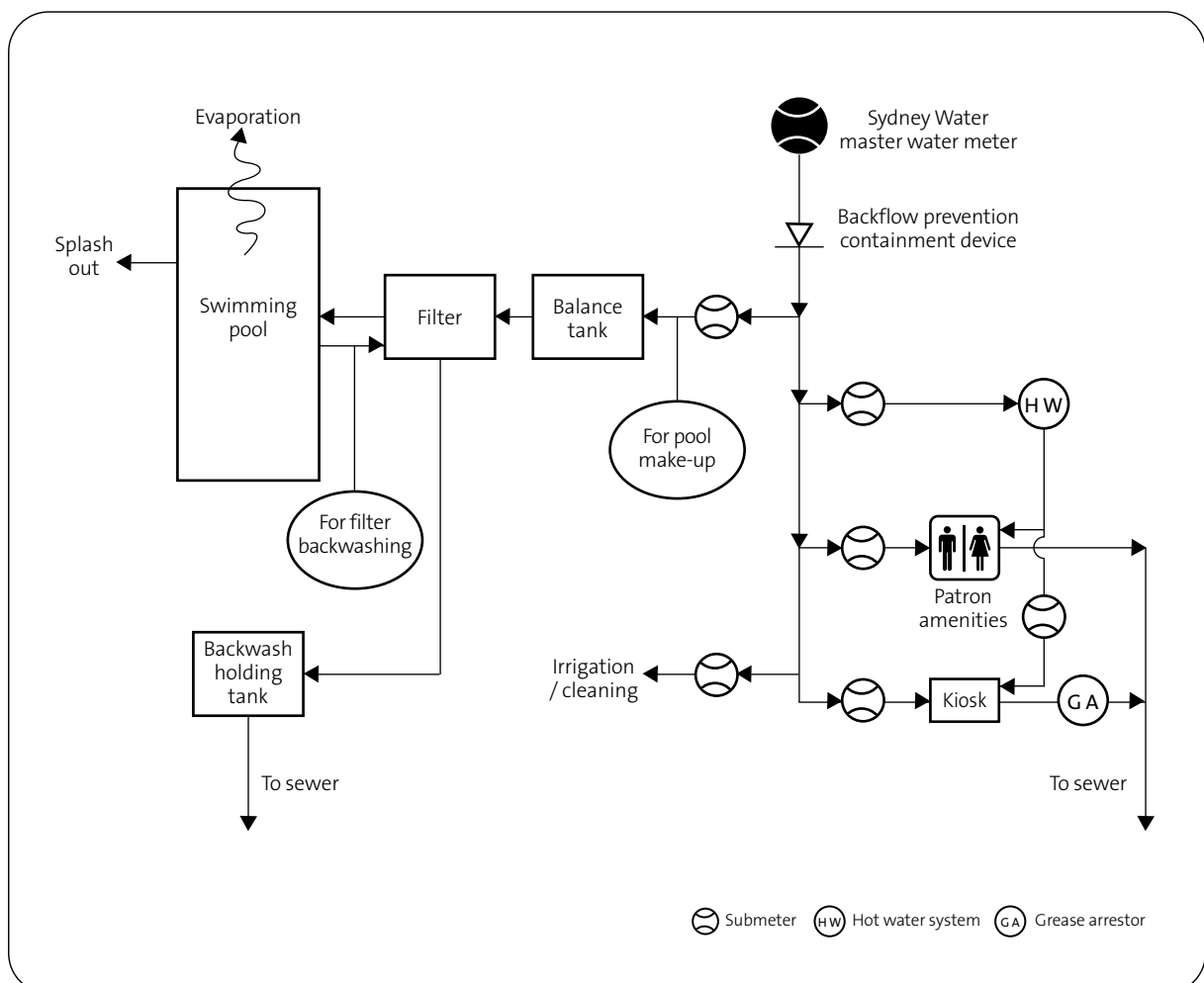

Figure 9 – Aquatic centre hydraulic diagram. Once you have calculated and graphed your water balance, it is easier to identify and prioritise your best opportunities to save water

## Chapter 9

# Action plans

Once you have measured and compared your centre's water use to best practice benchmarks, develop an action plan. The action plan will prioritise your water efficiency projects and any financial investment. Some factors to consider when prioritising projects include:

- funding availability
- water and energy savings
- cost saving
- health requirement
- compliance and legal requirements
- customer and tenant demand
- technical requirements and the abilities of your team
- whether they are achievable.

By understanding your priorities, you can develop a water efficiency plan with clear objectives and achievable targets.

Formal processes for setting action plans are a key part of best practice water management.

### Think laterally

In aquatic centres, energy and water use are linked. By using simple measures to maintain temperature and humidity within your centre, you can reduce the load on

your heating and ventilation system, reduce evaporation in your pool and prevent corrosion of internal pool hall components. This reduces water loss and saves on water and energy bills.

Think of other things you can do in your centre that may indirectly reduce water use, such as capturing and re-using condensate from boilers. Reducing water use can also save on chemical use, chemical treatment costs and cleaning operations.

### Review your progress

Regularly reviewing your water efficiency progress means you can report on:

- how much water you have saved
- how your water savings have affected your KPIs
- the costs and benefits of your actions
- the success and challenges of implementing water efficiency projects.

Reviews help you re-focus and prioritise water efficiency projects. It is important to approach water efficiency in a simple and systematic way. Continual improvement is a key element of best practice water management.

### Develop a resource management plan

A resource management plan is important to ensure ongoing, sustainable use of resources, such as water, energy and staff. It also allows you to assign resource responsibilities, plan projects and manage disruptions and business risk.

The following should be included in your resource management plan:

- Baseline water and energy use
- Water and energy saving targets
- Resources and responsibilities
- Training
- Water and energy saving projects
- Budgets and timeframes
- Risks
- Monitoring and reporting
- Quality compliance requirements
- Backwash schedules
- Maintenance schedules

The resource plan needs to be reviewed yearly to track progress towards achieving goals and to prioritise projects.

## Chapter 10

# Managing staff and contractors

Some council aquatic centres are managed by an external facilities management organisation. This can cause problems, such as operators:

- not understanding or complying with the council's sustainability objectives
- not understanding or sharing water or energy responsibilities
- not being held accountable for water or energy use and costs.

To improve the sustainability performance of council aquatic centres, managed both in house and externally:

- develop and drive the resource management plan with your aquatic centre facility manager
- ensure your lease arrangement clearly states responsibilities and performance targets for water and energy
- have formal monthly or quarterly meetings with agenda and minutes to check on facility sustainability performance and address issues

- hold yearly water and energy assessments at your aquatic centre to inform and align aquatic centre managers with your council's sustainability objectives. Create a management plan together and involve your Sydney Water Business Customer Services representative
- include targets, KPIs and key responsibilities in job descriptions or contracts to hold aquatic centre facility managers accountable for water and energy use or costs
- hold aquatic centre managers or external facility management organisations accountable for assigned water and energy KPIs and targets at performance reviews
- consider a lease arrangement based on efficiency and CO<sub>2</sub> emission performance.

## Chapter 11

# Justifying water efficiency projects

Once all these costs have been quantified, you may need to develop a business case to justify water efficiency projects identified from water efficiency audits and water management plans. By carefully calculating the true cost of your water, cost savings associated with water efficiency can be used to accurately calculate payback periods.

Other factors to help support your business case include:

- responding to future energy and water cost increases
- understanding the needs and values of your community.

### Responding to future cost increases

Over the last five years, the cost of water has almost doubled. As water and fuel become scarcer, the cost of water and energy is likely to increase more rapidly. By becoming water efficient now, businesses are better prepared for and more resilient to these cost increases.

To reflect increasing water prices, consider incorporating a 10% increase into your calculations of future water charges where these are not available. This will show how making water savings now is more cost effective than waiting until charges go up.

### Understanding the needs and values of your community

A proactive approach to water efficiency will show your centre shares community expectations about the environment. Audits by Sydney Water show many aquatic centres can implement water efficiency projects that will pay for themselves in less than two years. Managing water better, simple retrofitting, and capturing and re-using rainwater have achieved water savings.

Certain issues within some communities may be more important than in others. Your community may prioritise energy savings over water savings or may be more interested in reducing costs or improving services at a facility. It may be helpful to frame your business case from a different perspective to secure community support or external funding, such as focusing on the cost reduction or energy savings of a project.

## Chapter 12

# Sustainability and funding opportunities

Calculating the true cost of water can help build a strong business case for making your centre more efficient. A general rule for prioritising water efficiency projects is: avoid, reduce, re-use and recycle.

Many water efficiency projects are more cost effective than first expected if water, wastewater discharge and other operating costs are considered. The most effective water efficiency projects have short paybacks (from several months to three years), making them excellent candidates for internal funding approval.

Sometimes it can be difficult internally to fund more expensive or technically advanced water efficiency projects. If you need financial support for water efficiency projects, there are funding programs available. Some of these are listed below.

### Revolving funds for water and energy efficiency

Internal funding for sustainability projects can be secured by using a revolving fund. Monetary savings made by implementing sustainability projects are deposited into a designated

fund – the revolving fund. These funds are then used to undertake further sustainability projects that will also attract revenue for the revolving fund through further savings.

To make the revolving fund work, it is important to only fund the most cost effective sustainability projects with the shortest payback periods first. This ensures the fund is sustainable. Talk with your finance section to develop a revolving fund.

### Environmental levies

An environmental levy is an additional fee on top of property rates, charged to residents in a council area. The additional money generated from the levy is used to fund resource efficiency projects and improve the natural environment in the local government area.

If you are thinking of including an environmental levy in council rates, consider getting the community involved. Letting residents have a say in what projects are funded by the levy reduces opposition to the extra charge.

### Useful references

Australian Leisure Facilities Association (ALFA) 2010, About Us, [www.alfaleisure.org.au/default.asp?PageID=10&n=About+Us](http://www.alfaleisure.org.au/default.asp?PageID=10&n=About+Us)

Commonwealth of Australia, *National Greenhouse and Energy Reporting (Measurement) Determination 2008 (Schedule 1)*, [http://www.austlii.edu.au/au/legis/cth/consol\\_reg/ngaerr2008512/s1.03.html](http://www.austlii.edu.au/au/legis/cth/consol_reg/ngaerr2008512/s1.03.html)

Commonwealth of Australia, *National Greenhouse and Energy Reporting (Measurement) Amendment Determination 2009 (No.1)*, [http://www.comlaw.gov.au/ComLaw/Legislation/LegislativeInstrument1.nsf/0/778FBOF2BBACC03ECA2575E1000B8E44/\\$file/F2009L02571.pdf](http://www.comlaw.gov.au/ComLaw/Legislation/LegislativeInstrument1.nsf/0/778FBOF2BBACC03ECA2575E1000B8E44/$file/F2009L02571.pdf)

The Aquatic and Recreation Institute NSW (ARI NSW) 2010, Creating healthy and Active Communities, [http://www.aquaticinstitute.com.au/images/downloads/ari\\_advocacy.pdf](http://www.aquaticinstitute.com.au/images/downloads/ari_advocacy.pdf)





# Part 2

## Leaks and swimming pool operation

Part 2 of ***Best practice guidelines for water management in aquatic leisure centres*** is aimed at facility and aquatic centre managers and swimming pool operators. It describes practical steps you can take to reduce leaks and improve pool-operating practices to reduce water and energy use.

## Introduction

Most of the water and energy used in an aquatic centre relates to leaks and swimming pool operation. Figures 10 and 11 (also shown in Part 1) show the water and energy use breakdown of a typical aquatic centre. Twenty-two per cent of water is wasted through leaks. Thirty-six per cent of water is used in pool make-up and includes water used for backwashing filters. Wasting water through leaks and poor pool operation also wastes the energy used to heat and pump the water.

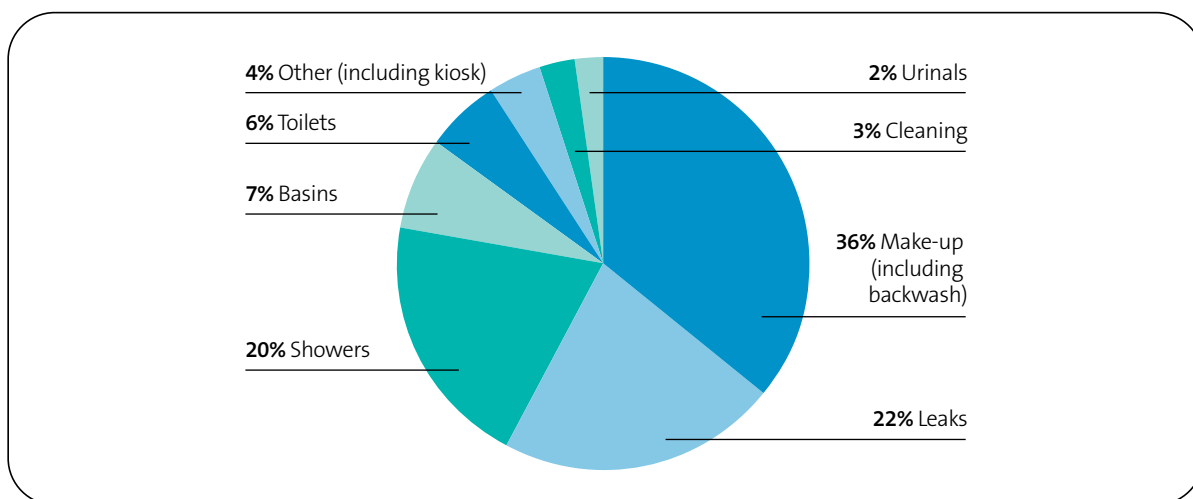

Figure 10 – Water use breakdown of a typical aquatic centre. Most water is used in pool make-up or wasted through leaks.

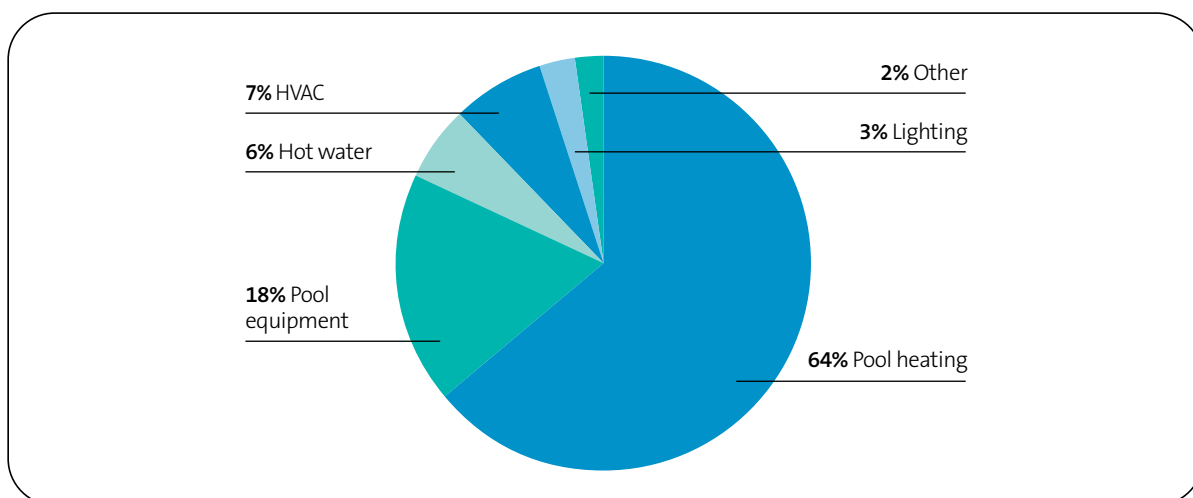

Figure 11 – Energy use breakdown of a typical aquatic centre. Wasting water through leaks or pool operations also wastes the energy used for pool heating.

## Chapter 13

# Leaks and base flows

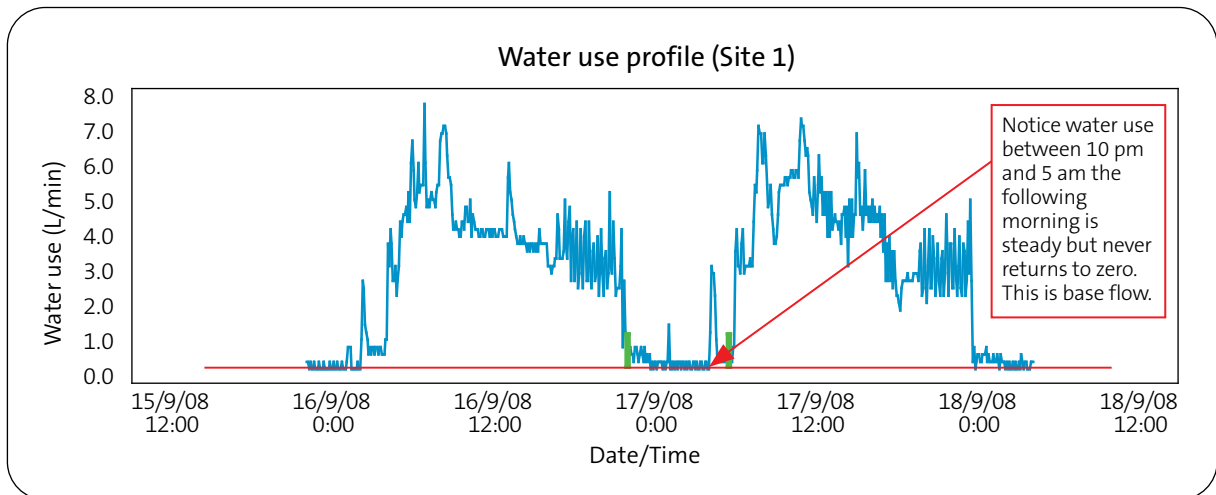

Figure 12 – Site water use monitoring profile indicating a base flow. On average 22% is wasted through leaks and base flow

Aquatic centres in Sydney waste an average 22% of total water use through leaks and base flows.

Leaks are visible or hidden and occur when water is lost through cracks or faulty components in the plumbing system. Leaks are either static or pressure.

- Static leaks have a constant loss of water.
- Pressure leaks are caused by a pressurised system when the system is operating.

Base flow is overnight or unaccounted for water use identified by monitoring.

In aquatic centres a base flow may occur from normal operation of cooling towers or pool make-up. If a base flow is unaccounted for, it could be a concealed leak,

faulty pool equipment, leaking amenities or amenities left on.

Figure 12 shows a site water use monitoring profile where a base flow has been identified. The monitoring time line helps to narrow down the cause of the base flow. The flow never returns to zero – even overnight when the site is closed and no equipment is being used.

### Visible leaks

Visible leaks in aquatic centres can occur in:

- toilets
- urinals
- showers
- kitchen sinks and dishwashers
- leaking pipes in the plant room.

Ask your customers and staff, including cleaners and contractors, to formally report leaks. This is an easy way to ensure leaks are identified, reported and repaired quickly.

One leaking tap can waste up to 221,000 litres a year. For an aquatic centre with multiple leaking taps, this could be very costly.

Leaks from hot water sources (showers, basins and kitchens) can cost thousands of dollars a year in water and energy. These costs include the cost of the metered water, wastewater discharge, trade wastewater charges (if applicable), and energy.

## Hidden leaks

Some leaks are not visible and hard to detect. Most aquatic centres have complex underground plumbing networks that make it hard to identify, locate and repair hidden leaks. Figure 13 shows the circulation system of a typical commercial pool. In many cases, underground leaks can drain into the wastewater system, stormwater systems or nearby creeks.

In the pool circulation system, leaks can occur in the pool structure or the pool circulation plumbing and equipment. A cracked pool shell or split pool water supply line can lose millions of litres of water a year.

## Pool structure

Common indicators of leaks in the pool and balance tank structure include:

- cracks in the pool or balance tank shell or visible structural damage
- rust staining on pool shell walls, around light fittings or inside gutters
- loose pool tiles, dislodged and missing grout.

Structural damage can occur when the pool is emptied and re-filled, when changes in temperature cause the pool shell and joints to expand and contract, and when there is ground movement. These can put pressure on the pool shell and joints, causing them to crack.

## Pool and balance tank shells

Areas of rust sometimes indicate leaking structures. Loose or missing pool tiles or missing tile grout are also an indicator of leaks. Inspect and repair missing tiles and grout regularly.

## Expansion joints

Large pool shells require expansion joints to connect the pool shell and pool circulation system. These may fail at certain points causing large leaks. Rust and loose tiles around expansion joints indicate leaks. Inspect and maintain expansion joints regularly. See the case study opposite.

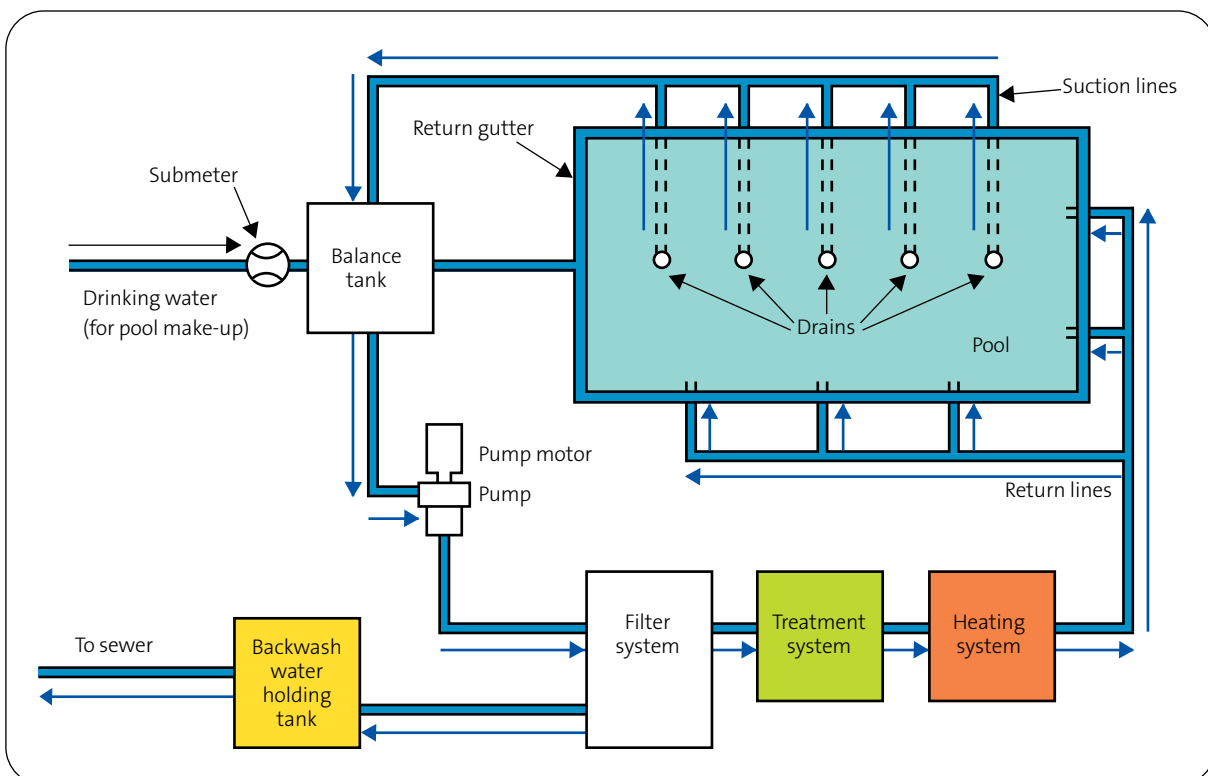

Figure 13 – Circulation system of a typical commercial pool

## Case study

### Swimming pool tile repair

Staff at Melbourne Sports and Aquatic Centre (MSAC) in Albert Park, Victoria, inspect and replace the tiles in their swimming pool each fortnight. MSAC uses scuba divers to carry out tile maintenance rather than empty the 75 metre pool. This means the pool can stay open during maintenance, causing minimal disruption to business.

South East Water in Melbourne reports that emptying the pool for repairs would waste up to 5 million litres of water. The risk of structural cracks from external pressure on the pool shell is also reduced.

## Case study

### Leaking expansion joint

An Olympic pool audited by Sydney Water had a leak of 70 kL/day in the top half of the shell. The cause of the leak was failure of waterproofing in the shell wall expansion joint as evidenced by falling tiles.

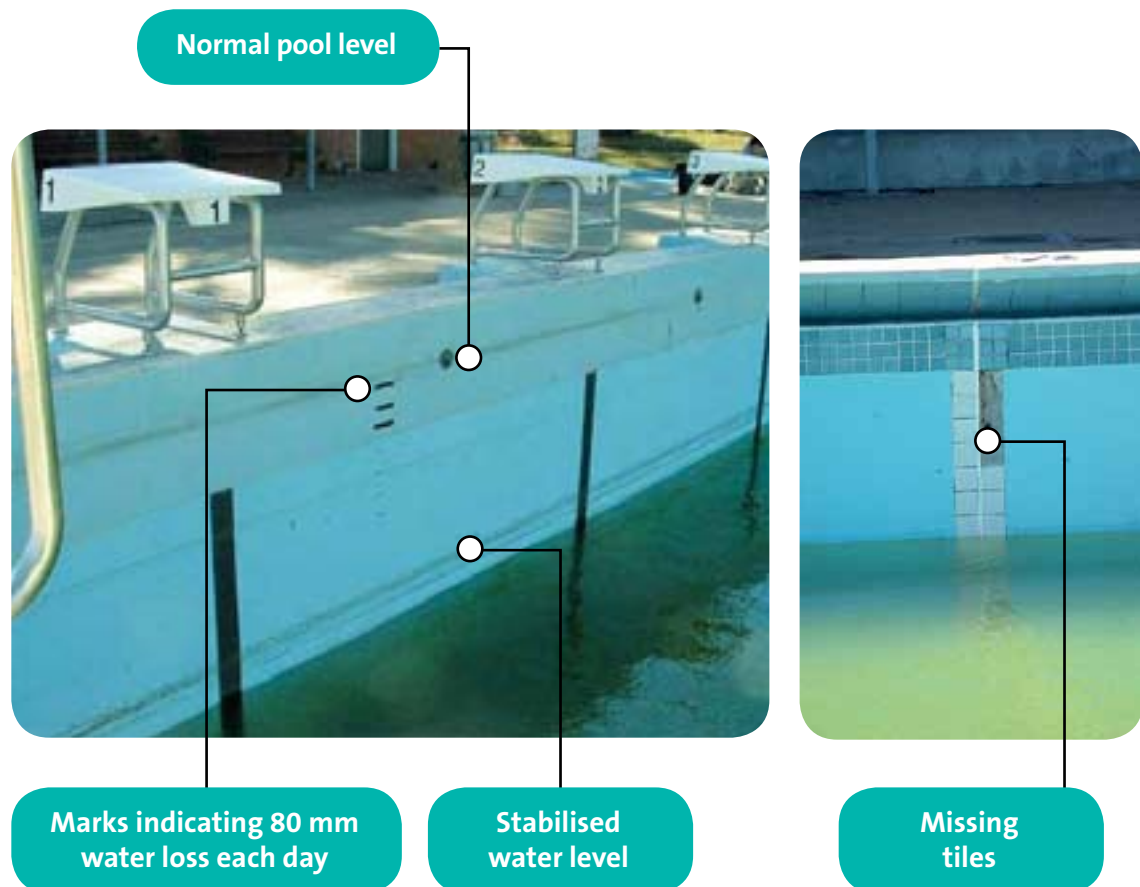

### Recessed pool lights and other fittings

Leaks in these areas can also be indicated by rust. You can test for leaks by applying dye around the outside of fittings and suspected cracks. Leaks are revealed when the dye disappears out of the pool through the fitting or crack.

### Pool gutters and skimmers

Both gutters and skimmer boxes are made from steel reinforced concrete and run along the pool perimeter to collect and feed water back to the balance tank to supply the circulation pump suction line. Modern pools use more accessible deck-level gutters.

Older, recessed gutter areas and skimmer boxes are difficult to inspect. Cracks in the shell can corrode steel reinforcing. Rust stains around joins or cracks can indicate leaks.



Below deck, recessed gutter made from steel reinforced concrete



Modern pools use more accessible deck-level gutters

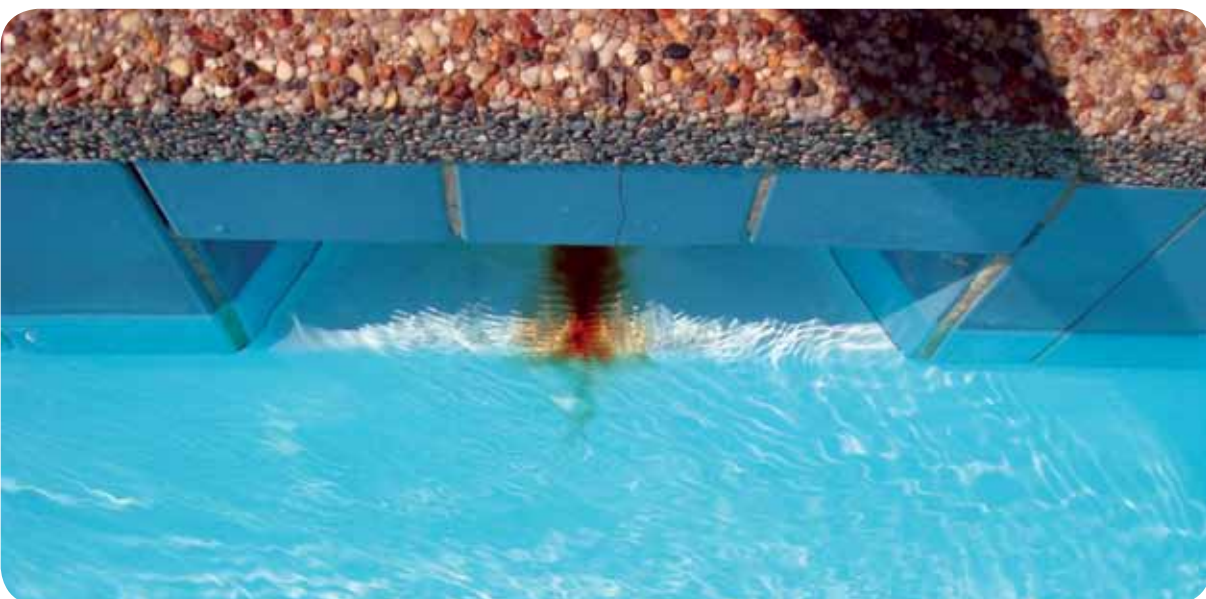

Rust stain on a concrete skimmer box shows corrosion in the steel reinforcing, indicating a leak

## Pool circulation plumbing and equipment

Common indicators of leaks in the pool circulation and plumbing equipment include:

- puddles under or around equipment in the plant room
- pool decking sinking or lifting
- soggy spots around the pool
- soggy or patchy, green grassy areas
- steady flows in drain lines.

These are caused by faulty:

- suction or pressure return lines
- water treatment equipment
- drain and backwash valves
- faulty bleed valves
- pumps and pump glands.

Some pump glands are designed to leak a specific amount of water to maintain a pressure seal. You must perform regular maintenance of the pump and gland to prevent excessive and unnecessary water loss. You can also replace these glands with a mechanical seal to stop water loss completely.

## Locating leaks

To confirm if you have a leak in the pool shell or circulation plumbing, conduct the following test.

### The bucket test

Turn off the make-up water supply and place a large bucket of pool water in the pool. Make sure the water level inside the bucket matches the water level outside the bucket and mark this on the bucket. Leave the circulation pumps on and compare the water levels inside and outside the bucket in the morning. If the water level outside the bucket has gone down by more than the water level inside the bucket, the pool system has a leak.

Once you confirm you have a leak, you must locate it. Conduct the following tests to find your leak. Remember – there may be more than one.

## Pool shell, balance tank and/or pipe systems

Repeat the bucket test with the pool pumps turned off. Also mark the water level in the balance tank at the start of the test. If the loss from the pool is exactly the same as in the first test when the pumps were on, then the leak should be in the pool shell. If there is no pool water loss, the leak should be in the pressurised parts of the system and/or the balance tank.

If the water level in the balance tank has not dropped, then the leak is most likely in the pressurised parts of the system. If the balance tank level has fallen, it has a leak. But if this does not account for all the losses indicated by the first bucket test, there may be additional leaks in the pressurised parts of the circulation system.

If a balance tank leak is suspected, you must monitor after hours make-up water use with the pool pumps off. This requires a make-up submeter, fitted with data logging equipment. Water use during this period indicates a leak in the balance tank and/or possibly part of the return (suction) piping from the balance tank.

You can check the return piping for leaks by isolating it at the balance tank with a valve or a temporary plug, and then observing the make-up water use after hours compared to when it was not isolated.

**Pressure and suction lines**

Pressure testing is a cost effective way to locate leaks in pressure and return lines. Use existing isolation valves or temporary plugs to isolate different parts of the system. Pressurise each isolated section – pressure drops indicate a leak.

**Underground pool circulation leaks**

Leaks in the pipe work may be hard to locate, because

pipes can be buried under pool decking or hidden under or behind infrastructure. Where sections of pipe work are not exposed, you can use acoustic detection equipment to pinpoint the location of leaks, and where to dig. If the pool water is heated, you can also use infrared detection for locating underground leaks.

If you cannot locate the leaks, contact a leak detection specialist. There will be an upfront cost, but it is a good

investment. Finding and fixing leaks quickly can save you hundreds of dollars a day.

**Measuring your leak**

Depending on the size of your leak, you can calculate the water and money wasted. Figure 14 shows the daily cost of a water leak based on water and wastewater use charges (2010-11). Additional costs depend on the water treatment and energy used for heating and pumping the wasted water.

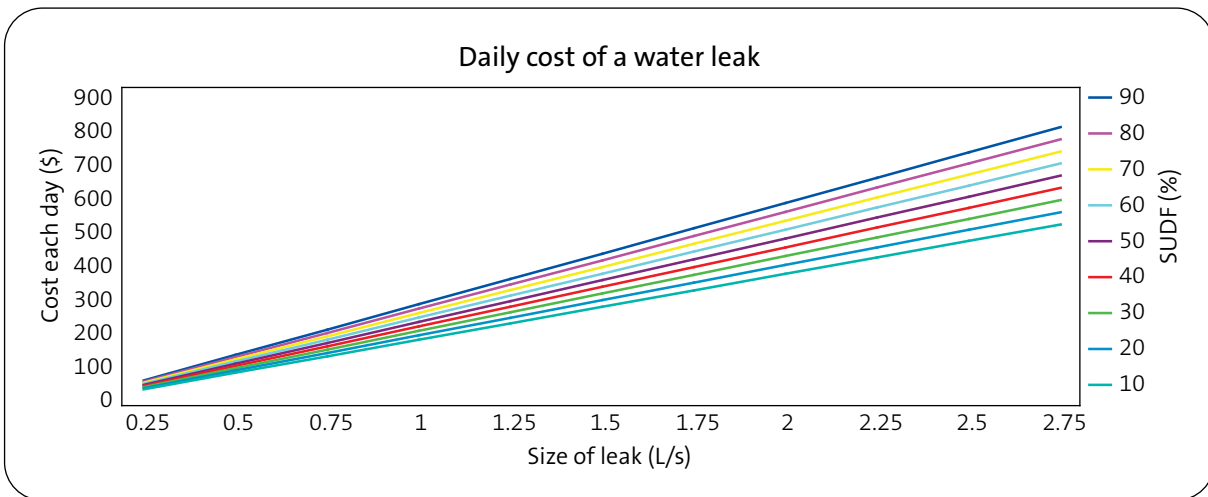

Figure 14 – By fixing leaks, you can make huge cost savings in water and wastewater use charges



## Case study

### Fixing a concealed leak at Canterbury Pool

After identifying a base flow through monitoring at Canterbury Pool, the council engaged Sydney Water to help identify its source. An initial site inspection eliminated obvious causes and there were no leaking amenities or unusual operational practices observed. A leak detection company was employed to investigate a possible concealed leak. Over a period of two days the leak location was narrowed to an area of two square metres under a concrete slab. The 2.5 L/s leak was flowing into an old decommissioned pool, which had been filled in.

The repair work included excavation, capping the burst pipe and restoring the site to its original condition. Finding and fixing the leak quickly helped save the council over \$600 a day in water and wastewater costs. The payback for their investment to find and fix the leak was less than one week.



## Managing leaks

There are a number of signs that may indicate a leak:

- increased water use
- increased or erratic chemical use
- constant supply line flows when pools are not in use
- air in the pool circulation system.

Use a systematic, coordinated approach to identify and locate leaks and base flows.

**Table 4 – Checklist for managing leaks**

Activity	Systematic approach	How often
<b>Check your water bill</b>	<ul style="list-style-type: none"> <li>• Compare water bills from the same period in the previous year as well as the bill for the previous month or quarter.</li> <li>• Calculate and compare your KPI of kL/patron/day against the previous month, against your target, and against other similar centres.</li> </ul>	Monthly/ Quarterly
<b>Monitoring</b>	<ul style="list-style-type: none"> <li>• Install submeters to the water supply serving swimming pool balance tanks, kitchens and amenities.</li> <li>• Read your water meters daily or at least on the same day every week.</li> <li>• Read your water meters after cleaning at night and in the morning before opening. Any unexplained difference may indicate a leak.</li> <li>• Install offline or online monitoring equipment which will provide you with real time monitoring data (refer to Chapter 6).</li> </ul>	Daily
<b>Visual inspection</b>	<ul style="list-style-type: none"> <li>• Conduct a routine inspection to check for visible leaks. Check all amenities, kitchens and outdoor areas and look for leaking taps, showers, toilet and urinals.</li> </ul>	Daily: early morning or evening
<b>Maintenance inspections</b>	<ul style="list-style-type: none"> <li>• Conduct detailed maintenance inspections to identify undetected leaks. Align these with your backwash, clean up or OHS routine. Make sure you:               <ul style="list-style-type: none"> <li>– check the pool structure                   <ul style="list-style-type: none"> <li>• Pool shell (eg expansion joints)</li> <li>• Pool shell fittings (eg lights)</li> <li>• Balance tank and float valves</li> <li>• Gutters</li> </ul> </li> <li>– check pool circulation plumbing and equipment                   <ul style="list-style-type: none"> <li>• Suction and pressure (return) lines</li> <li>• Water treatment equipment</li> <li>• Drain and backwash valves</li> <li>• Pumps and pump glands</li> </ul> </li> </ul> </li> </ul>	Weekly

Activity	Systematic approach	How often
<b>Contractors and staff awareness and training</b>	<ul style="list-style-type: none"> <li>• Inform contractors and staff of their roles and responsibilities.</li> <li>• Communicate your water efficiency KPIs to contractors and their staff, especially maintenance and cleaning contractors.</li> <li>• Ask contractors to alert you to problems as soon as possible, and to document issues in written reports.</li> <li>• Give maintenance staff a limited pre-approved budget so they can quickly buy equipment to make essential repairs.</li> </ul>	Monthly/ Quarterly
<b>Planned or proactive maintenance</b>	<ul style="list-style-type: none"> <li>• Regularly replace sensor batteries, tap washers and other consumables before they fail. Use manufacturers' guidelines or past experience to schedule work. This will help stop leaks and better organise budgets and work schedules.</li> </ul>	Quarterly/ Yearly



One leaking tap can waste up to 221,000 litres of water a year

## Chapter 14

# Saving water from treatment

Pool water treatment systems and practices result in a need to add fresh make-up water to maintain quality. However, there are options that achieve superior water quality while also saving water and energy.

Water quality is arguably the most important aspect of aquatic centre operation. Clean, clear and healthy water attracts bathers and maintains bather safety.

To ensure water is clean and clear, you must filter and disinfect it. Filters remove particles from the water as it circulates through. However, pathogens (micro-organisms) are too small to be removed by the filter, so disinfection is required.

### Disinfection

Disinfection kills pathogens and prevents them from being passed from bather to bather. Chlorination is widely used to disinfect pool water. It not only kills the pathogens at the time of treatment, but leaves residual chlorine (free chlorine) in the water, helping to keep the water free from pathogens.

Chlorination is generally achieved by adding sodium or calcium hypochlorite to the water. Some aquatic centres supplement chlorination with ultraviolet (UV) light irradiation or ozone treatment for extra protection.

### TDS

The need to continually add chemicals to pool water causes build up of residual salts or total dissolved solids (TDS). TDS indicates how salty the pool water is and can also affect the clarity of the water.

### Chloramines

Chloramines (combined chlorines) result when amino acids from bather sweat and urine in the pool water combine with residual chlorine (free chlorine). They can be monochloramines, dichloramines or trichloramines. Chloramines reduce the amount of available free chlorine for disinfection.

Chloramines are a major problem for indoor pools. High chloramines can cause eye and throat irritations in bathers and create unpleasant odours. Chloramines also corrode handrails, ladders, exposed steel structural elements and HVAC components. In outdoor pools, ultra violet light from the sun destroys chloramines by photolysis and photo-oxidation.

### Pool water balance

To mitigate the build up of TDS and chloramines, some of the highly concentrated water is discharged from the pool and the pool is topped up with fresh drinking water (pool make-up). This occurs in addition to water added for pool make-up after pool water is used in backwashing the filters.

Every time pool make-up is needed, water, heat energy and chemicals are needed. By maintaining water balance and understanding and optimising water treatment in your centre, you will need to dilute pool water less often, saving water, energy and chemicals while maintaining water quality.

### Turbidity

Turbidity is a measure of the suspended material in the water and may cause it to look cloudy or discoloured. The lower the turbidity, the more effective the disinfection. Effective filtration removes suspended material and improves disinfection.

## Water treatment chemicals in Australia

The most common types of pool disinfection used in Australian pools are:

- sodium hypochlorite (liquid)
- calcium hypochlorite (granular or tablet).

These can be supplemented by additional treatments, such as:

- UV light irradiation
- ozone treatment.

Magnesium salt is emerging as an alternative chemical treatment in commercial aquatic centres. In the past, chlorine gas and dichloroisocyanurate and trichloroisocyanurate have also been used as pool sanitisers, but are now rarely used in commercial pools.

## Sodium hypochlorite

This is the most common sanitising agent. Liquid sodium hypochlorite, (sodium hypo) is delivered to the pool by automatic dosing pumps. Sodium hypochlorite dissolves in the water to form a solution of hypochlorous acid (free chlorine), a powerful oxidant. Free chlorine acts to oxidise organic matter and kill pathogens quickly. Some of the free chlorine remains in the water as a residual to kill any new pathogens that enter the pool before they can infect other bathers.

The active chlorine levels for this form of sanitiser are low, around 10–15%. This means that relatively large volumes are needed to maintain water quality and a sufficient residual. Total dissolved solids (TDS) can build up quickly due to the sodium salts. To maintain the TDS at an acceptable level, fresh water must be added to dilute it. Make-up water added to the pool after filter backwashing may already meet this dilution requirement. However, extra backwashes are often performed unnecessarily to add dilution water to the pool.

Liquid sodium hypochlorite is classified as a dangerous good Class 8 corrosive. Pools using sodium hypochlorite must comply with occupational health and safety regulations that apply to its delivery, storage and use. These requirements are set out in WorkCover New South Wales, *Storage and handling of dangerous goods, code of practice* and *Australian Standard AS 3780-1994, the storage and handling of corrosive substances*.

### Calcium hypochlorite

Calcium hypochlorite is becoming more popular as a sanitising agent in commercial pools. Over the last ten years, over 300 dry calcium hypochlorite dosing systems have been installed Australia-wide. Calcium hypochlorite comes in tablets or dry granular form. Dry calcium hypochlorite is added into a mixing tank containing pool water and forms a solution. This solution is then introduced to the pool through a feeder. The method of sanitation is the same as for sodium hypochlorite.

Earlier commercial dry calcium hypochlorite feeders were based on simple domestic calcium hypochlorite feeders and had problems with the feeder unit clogging up due to scaling. There are at least two newer commercial dry calcium hypochlorite feeders on the market today that use acid dosing to stop the feeder clogging up. The acid dosing can also assist or replace existing acid dosing equipment used to control the pH component of the water balance. Hydrochloric acid may also add to the free chlorides in the pool.

Compared to sodium hypochlorite, calcium hypochlorite is 65% active and very stable. The lower proportion of calcium salts means that TDS builds up more slowly than for sodium hypochlorite and less dilution water is needed to mitigate it.



Dry calcium hypochlorite dosing system at Springwood Aquatic Centre. Over the past 10 years, over 300 similar systems have been installed Australia-wide

Dry calcium hypochlorite is classified as a dangerous Class 5.1 oxidising agent. Occupational health and safety regulations for delivery, storage and use differ to those for sodium hypochlorite. Some pool operators find it easier to comply with the regulatory requirements for dry calcium hypochlorite than those for

liquid sodium hypochlorite.

Pools using dry calcium hypochlorite must comply with the requirements set out in the WorkCover New South Wales, *Storage and handling of dangerous goods, code of practice* and Australian Standard AS 4326-2008, *the storage and handling of oxidizing agents*.

### Magnesium salt

Suppliers of this new way of sanitising pool water claim benefits in water savings and water quality. It is already accepted in some domestic pool markets and is now appearing in commercial pools. This system uses an electrolytic chlorine generator to create sanitiser from a blend of magnesium chloride and other trace elements.

In Australia, there is limited detailed and independent information available to support the claims by suppliers. Manufacturers claim that due to the presence of magnesium hydroxide, a good coagulant, in the treated pool water, there is improved filter efficiency. This results in:

- reduced filter backwash frequency
- reduced turbidity
- reduced chloramines
- improved clarity.

In addition, manufacturers claim that the use of magnesium mineral salt eliminates skin, eye and nose irritations associated with the use of sodium or calcium hypochlorite.

### Supplementary treatment

Both ozone and UV can be used in pool water treatment, but must be used in conjunction with chemical treatment. This is because, while they are powerful disinfectants, they do not leave a residual disinfectant in the water to prevent further

introduced contaminants being transmitted from bather to bather. By supplementing chemical treatment (chlorination), chemical use can be reduced. Other common benefits of both are that treatment:

- has greater disinfection effectiveness against bacteria and viruses compared to chlorination alone
- has no effect on pH or water balance
- does not contribute to TDS
- reduces chloramines.

### Ultraviolet (UV) treatment system

UV light is an effective water disinfectant and sanitiser. In pools, UV is used to supplement chlorination. It destroys the proteins, enzymes and DNA of micro-organisms that may not have been completely oxidised by chlorination. UV also destroys these compounds by photolysis and photo-oxidation. It is particularly useful in killing chlorine-resistant pathogens such as *Cryptosporidium* and other bacteria and viruses.



UV systems like this one at Ian Thorpe Aquatic Centre effectively disinfect and sanitise water

The selection and performance of a UV system depend on water flow rate, UV energy dose, water temperature, turbidity, water hardness, and level of suspended solids. These can reduce the transmission of UV light through the water, reducing UV's ability to disinfect. This may also lead to deposits of organic matter on the UV lamp.

Medium pressure, polychromatic lamps are best for swimming pools. They can handle variable flow rates and transmit UV light at a wide wavelength range. This increases the variety and type of contaminants UV can oxidise. Better UV systems have a range of power settings and automatic lamp sleeve cleaning.

UV is now a standard feature of most new and refurbished centres and is being increasingly fitted to existing

systems. Aquatic centres with indoor pools should consider UV treatment.

### Ozone

Ozone is a colourless gas (chemical formula  $O_3$ ). Ozone is a relatively unstable toxic gas and decomposes to re-form oxygen. It is a powerful oxidiser, acting on pathogens and organic waste in pool water to break them down quickly.

Some additional advantages of ozone include that it can:

- sterilise in turbid conditions (unlike UV)
- sterilise close to 100%, when used with inlet filtration of less than 40 microns.

An ozone plant requires an ozone generator, compressor, refrigeration dryers, controls and a switchboard. Water needs to be cooled and treated with ozone. The water is then re-heated to break down the ozone before it is introduced back into the pool.

All traces of ozone must be used or removed from the water before it reaches the pool to prevent it coming into contact with bathers.

There are disadvantages that limit the use of ozone in commercial pools in Australia. These include:

- the size and cost of the treatment system
- the complexity of its set up and operation
- high ongoing operational and maintenance costs
- increased energy use
- potential health effects from human exposure to ozone gas.

### Water treatment comparison table

Table 5 compares different water treatment chemicals and technologies and shows what to consider before using or installing these.

**Table 5 – Water treatment comparison table**

Treatment chemical	Feature				Considerations
	Sanitise	Residual sanitation	Chloramine reduction	TDS contribution	
<b>Sodium hypochlorite</b>	Yes	Yes	No	High	<ul style="list-style-type: none"> <li>• Class 8, corrosive agent</li> <li>• Comes in bulk liquid form</li> <li>• Short shelf life, especially when exposed to light</li> <li>• Lower percentage of active chlorine so it has a higher impact on TDS</li> </ul>

Treatment chemical	Feature				
	Sanitise	Residual sanitation	Chloramine reduction	TDS contribution	Considerations
<b>Calcium hypochlorite</b>	Yes	Yes	No	Low	<ul style="list-style-type: none"> <li>• Class 5.1, oxidising agent</li> <li>• Comes in dry granular form (10 kg bags) or tablet form</li> <li>• Stable long shelf life</li> <li>• Higher percentage of active chlorine so it has a lower impact on TDS</li> <li>• Dosing systems with automatic acid cleaning are best</li> </ul>
<b>Magnesium salt</b>	Yes	Yes	Likely	High	<ul style="list-style-type: none"> <li>• Comes in dry granular form (10 kg bags)</li> <li>• Stable long shelf life</li> <li>• Has a higher impact on TDS, but this is required for its normal operating range (3,000-4,000 ppm)</li> <li>• Can be used for irrigation if diluted 5:1</li> <li>• May filter to 4-5 <math>\mu</math> due to enhanced flocculation by magnesium hydroxide</li> </ul>
<b>Ultraviolet (UV) treatment system</b>	Yes (secondary)	No	Yes	No – does not contribute	<ul style="list-style-type: none"> <li>• Medium pressure polychromatic lamps are best for use in aquatic centres</li> <li>• Choose systems with a self cleaning function</li> <li>• Operates poorly under turbid conditions</li> </ul>
<b>Ozone</b>	Yes (secondary)	No	Yes	No – does not contribute	<ul style="list-style-type: none"> <li>• Installation, operation and maintenance costs are high</li> <li>• High energy use</li> <li>• Operates well under turbid conditions</li> </ul>

## Chapter 15

# Saving water in filtration and make-up systems

Filter backwashing accounts for up to 40% of total water use in aquatic centres. Unnecessary filter backwashing wastes water, energy and chemicals because of the need to heat and treat the incoming make-up water.

Water filtration is an essential part of pool water treatment in aquatic centres. Pool water is continually circulated through the filters to capture contaminants. These include organic matter, such as hair and skin, small particles, such as sediment, dirt and leaves, oily residues from sunscreens and lotions, and harmful bacteria.

Backwashing unclogs the filters by pushing dirt and contaminants out. This involves reversing the flow of water through the filters. Filters need to be backwashed regularly to:

- keep them working efficiently
- maintain water quality and appearance
- maintain bather health and safety.

The backwash water then flows into a holding tank and is discharged to the wastewater system in a controlled manner. The duration, frequency and volume of water used in each backwashing cycle depend on the filter type, filter media

and operation of the filters during backwash.

### Filter types

There are a number of filter types and filter media on the market. The main filter types used in Australian aquatic centres are:

- gravity filters
- pressure filters
- pre-coat filters
- vacuum filters.

There are advantages and disadvantages to each type, which are summarised in Table 6. Table 6 also shows the typical volume and frequency used by a 50 m pool to backwash filters. The volume used for each cycle and each year varies, depending on backwash frequency, bather load, location (indoor or outdoor), the condition of the media and circulation rate.

### Gravity filter

Gravity filters are slow rate filters that rely on gravity to push water through the filter media, typically sand. These are mostly found on older 50 m outdoor Olympic pools. Gravity filters are large and require significant amounts of backwash water to clean the sand. The only cost effective option for improving the water efficiency of a gravity filter is to replace it with a more water efficient filter type.

### Pressure filters

Pressure filters (Figure 15) are the most common filters for commercial pools and are operated at medium and high rate pressure. They involve two to four filter vessels in parallel, each about two thirds filled with filtration media in layers of different particle sizes in the range of 0.5-1 mm. Water is forced through the filter bed and exits through the laterals (the perforated pipes at the bottom). The most common media used in pressure filters is sand.

It is the rate of flow through the media (usually sand) that matters. Medium rate filters operate in the range 20-30 kL/m<sup>2</sup>/hr while high rate ones operate at 30-50 kL/m<sup>2</sup>/hr. High rate filters are usually limited to clubs, hotels and private pools where bather load is relatively light. Public pools with high bather loads and a high proportion of children operate medium rate filters as the lower flow rates provide longer contact time for the water with the media and better filtration. Medium rate filters are larger than high rate pressure filters, but not as large as low rate gravity filters.

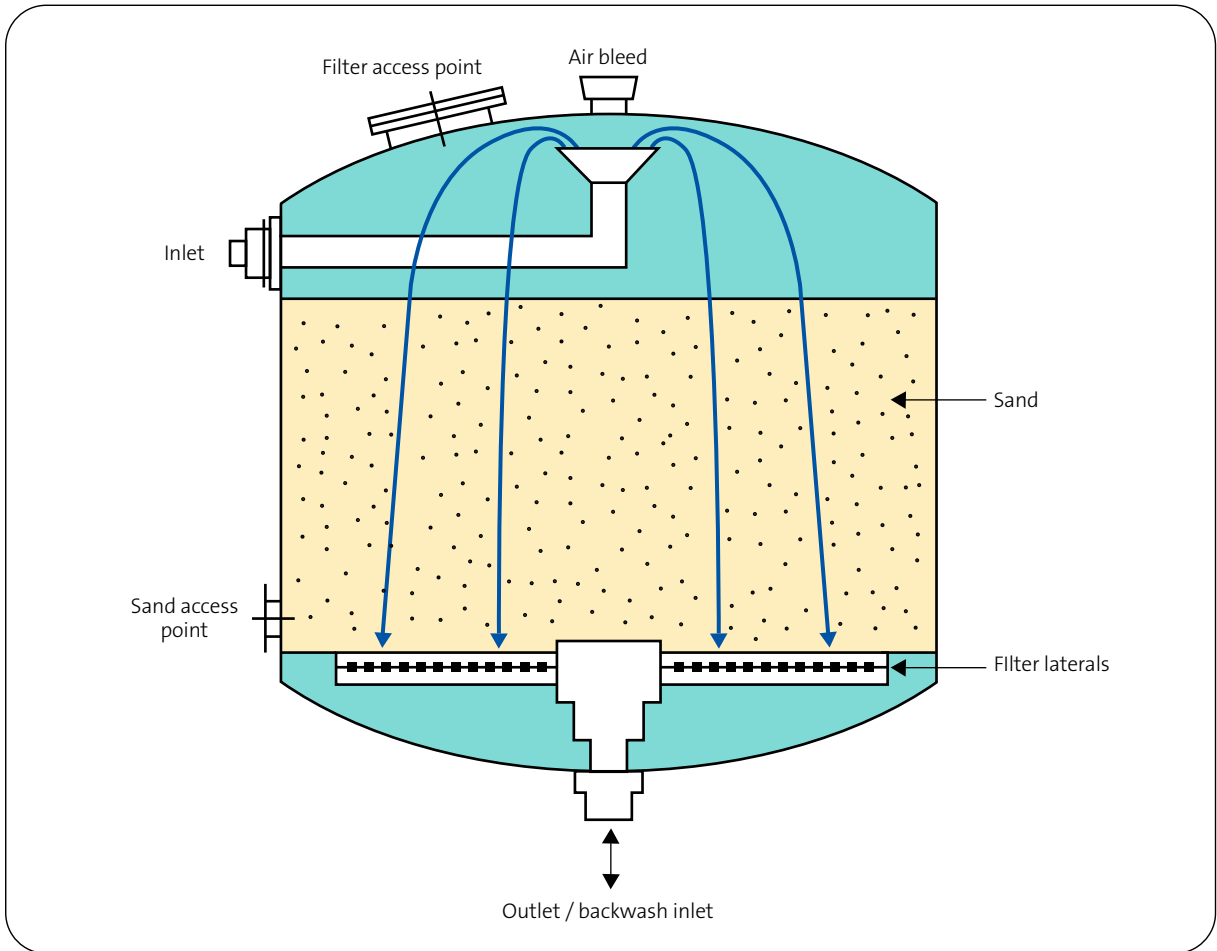

Figure 15 – Pressure filter



Pressure filters, like this one at Springwood Aquatic Centre are the most common commercial pool filters

### Pre-coat filters

Pre-coat filters (Figure 16) provide a very high level of filtration that creates water of low turbidity and high clarity. Diatomaceous earth (DE) is the most common pre-coat filter media, however perlite and cellulose fibre are also used. Filter media comes as a fine powder, which is mixed with water to form slurry that

is used to coat a filter sock or filaments. At the end of the filter cycle, the filter media is 'bumped' off the filter filaments and discarded.

Operating pre-coat filters is more complex and labour intensive than for gravity and pressure filter types, because the filter media is lost after each backwash and new media needs to be

added. Filter media removed in the backwash must also be collected and separately disposed of. Some pre-coat filters need the filter socks replaced each 12 to 18 months. There are alternative filter sock types that may last longer, and filter filaments are now entering the market that remove the need for filter socks completely.

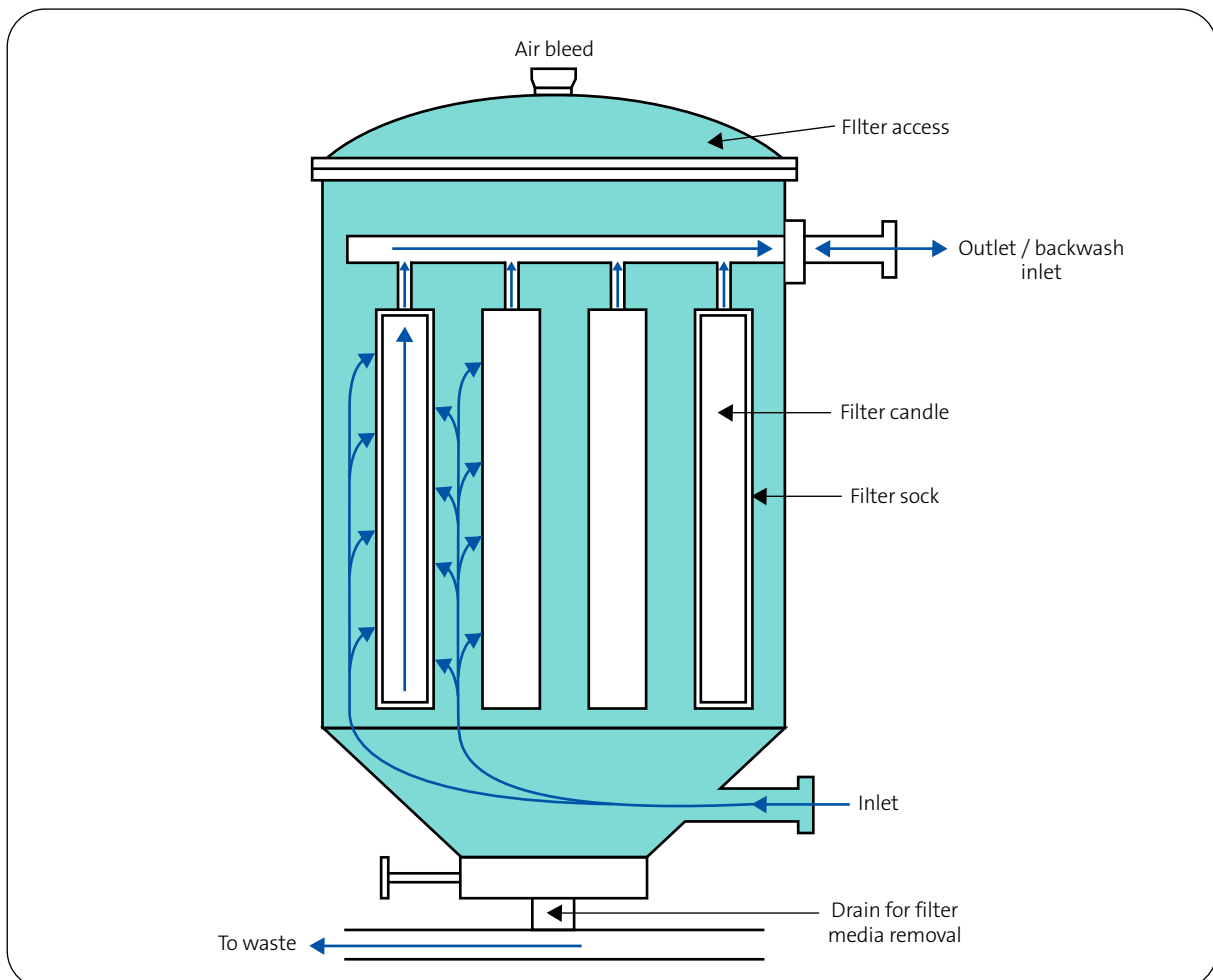

Figure 16 – Pre-coat filter

Image right – This pre-coat filter at Des Renford Aquatic Centre uses perlite filter media. The filter filaments don't need filter socks, saving money and time

**FILTER  
COMPETITION POOL**

**Defender**  
Professional Pool & Spa Equipment

OFF	ON	ON	OFF
WATER TREATMENT	WATER TREATMENT ON	FLOW MODE	
WATER TREATMENT	WATER TREATMENT ON	FLOW MODE	
WATER TREATMENT	WATER TREATMENT ON	FLOW MODE	
WATER TREATMENT	WATER TREATMENT ON	FLOW MODE	
WATER TREATMENT	WATER TREATMENT ON	FLOW MODE	
WATER TREATMENT	WATER TREATMENT ON	FLOW MODE	
WATER TREATMENT	WATER TREATMENT ON	FLOW MODE	
WATER TREATMENT	WATER TREATMENT ON	FLOW MODE	
WATER TREATMENT	WATER TREATMENT ON	FLOW MODE	

**MODEL RMF FILTER PROGRAMMER**

**Neptune-Benson**  
Professional Pool & Spa Equipment



PUMPS



### Vacuum filters

Vacuum filters are a low rate, open tank filter. Water is pumped into one end of a filter tank and drawn through the tank by pool water return pumps. The tank has a bank of removable filter elements coated with filtration media, commonly dry cellulose fibre. The element coating is automatically topped-up through a dosing hopper that is manually filled with the filtration media. This reduces

the need for filter cleaning and increases the effective life of the filter from 1–2 weeks to between 8–15 weeks.

Vacuum filters can filter down to 3–5 microns, depending on the filter media. To clean the filters, each tank is drained to a holding tank (7-10 kL) and the filter elements are hosed down (1-2 kL). Cleaning requires much less water than for backwashing gravity and pressure filters. Filter tanks usually take up less space

in a plant room. Vacuum filters are ideal for replacing gravity sand filters. The old filter structure can even be used to accommodate vacuum filter tanks cost effectively.

### Filter comparison table

Table 6 compares different types of commercial water filters and explains what to consider before using or installing these.

**Table 6 – Water filter comparison table**

Filter type	Features				
	Backwash or filter renewal	Water use per cycle (kL)	Filter cycle	Filter media	Considerations
Gravity	Backwash	50 to 100*	1-2 weeks	Sand	<ul style="list-style-type: none"> <li>• Old technology</li> <li>• Water inefficient</li> </ul>
Medium and high pressure	Backwash	30 to 50*	1-2 weeks	Sand Zeolite Glass	<ul style="list-style-type: none"> <li>• Filter laterals fail over time, but are difficult to inspect</li> <li>• Filter effectiveness falls if backwash practices are poor or flow rate is too high.</li> </ul>
Pre-coat	Filter renewal	15 to 20*	3-5 weeks	DE Perlite Cellulose	<ul style="list-style-type: none"> <li>• Normal filter socks are replaced every 12 months</li> <li>• New sock type is longer lasting (5-10 years) and may extend the filter cycle</li> <li>• Filter filaments don't use filter socks at all.</li> </ul>
Vacuum	Filter renewal	10 to 15*	10-15 weeks	Cellulose DE Perlite	<ul style="list-style-type: none"> <li>• Filter element socks are replaced every 7-10 years</li> <li>• Manual cleaning of filter elements is required (about one hour every 10 to 15 weeks)</li> </ul>

\* Based on 50 m pool



## Case studies

### Vacuum media filtration in Victoria

Waves Leisure Centre in Kingston, Victoria replaced the medium pressure sand filters on its indoor 50 metre and leisure pools with vacuum media filtration. The retrofit increased the filter cycle from one week to 10–12 weeks, saving 26 kL of water a day.

Croydon Memorial Pool replaced the gravity sand filter on its outdoor pool with vacuum media filtration. The filters need to be cleaned every two to three weeks due to wind blown debris and ducks entering the pool. Only 10 kL of water is used each time to clean the new filters, compared to 100 kL for the old filters. This saves Croydon Memorial Pool 90 kL of water each time the filters are cleaned.

(Photos courtesy Ian Coombes Australia).

## Filter media

There are various types of filter media available. The most common media used in pool filters are:

- sand
- sand alternatives (zeolite and glass)
- pre-coat media (diatomaceous earth, perlite and cellulose fibre).

### Sand

For the predominant pressure type filters, sand is by far the most used media; it is cheap and well understood. It can filter to 15 microns. However, its hardness is variable which impacts its effectiveness over time.

### Sand alternatives

The main alternatives for replacing sand media in medium and high pressure filters are zeolite and glass. At this stage, there is limited detailed and independent information available to support claims of benefits by suppliers. In Australia, there have been mixed reports on the performance of these media compared to sand. A local survey of several current users all reported good but unquantified results for both zeolite and glass media after six months to two years of use.

### Zeolite

Zeolite is derived mostly from volcanic rock and is common in water purification and wastewater treatment.

Zeolite removes impurities from the water by:

- absorption - conventional filtration where particles are physically trapped by the filter media
- adsorption - where organic and other substances are physically attracted to and form weak bonds with the surface of the filter media (it has a surface area of around 500 m<sup>2</sup>)
- ion exchange - where ammonium ions in the pool water are exchanged with sodium ions on the surface of the zeolite. This prevents combined chlorines forming.

Zeolite media needs to be regenerated yearly to remove the ammonium ions from the surface of the zeolite. Regeneration maintains the ability of the zeolite to remove impurities through adsorption and ion exchange. Regeneration involves taking the filters offline and soaking them with a 20% salt solution using sodium chloride (NaCl) for 6-12 hours overnight. After this has been done, the filter is backwashed as normal.

Some of the claimed benefits of zeolite include:

- easy installation
- lower density than sand (so less by weight is required)
- reduced chemicals required to treat the water
- enhanced performance of chlorine by reducing turbidity

- reduced pool odour, eye and skin irritation
- increased filtration efficiency, particle capture, removal
- longer lasting than sand as hardness is more uniform.

### Glass

Glass also has several claimed advantages over sand. In Australia, glass media is made from selected recyclable material. At this stage, there is limited detailed and independent information available to support claims by suppliers.

An Aquatic Commercial Industries Report (No GL-98-1) on a commercial pool in Washington (USA) determined that glass improved clarity by 25% to 0.27 NTU (Nephelometric Turbidity Unit) compared to 0.4 NTU for sand. Backwash water use was reduced by 23% and the filter required 20% less glass by volume to fill.

The Waste & Resources Action Programme (UK) conducted operating trials of the ability of glass versus sand media to remove solids from effluent. In all cases, glass proved equal or superior to sand.

Some of the claimed benefits are:

- easy installation
- lower density than sand, so less by weight is required
- reduced chemicals required to treat the water

- increased filtration efficiency (particle capture and removal)
- longer lasting than sand as hardness is more uniform.

### Pre-coat media

Pre-coat media include DE, perlite and cellulose. These media are relatively new to the commercial market so current levels of use are low. They have proven abilities to filter down to 3-5 microns, resulting in pool water with improved:

- appearance
- clarity
- ability to remove harmful organisms.

### Diatomaceous earth (DE)

Diatomaceous earth (DE) (naturally occurring or synthetic DE) can filter to 3-5 microns and uses typically

less than 1 ML a year for filter backwashing. The DE used in swimming pool filters is processed with a fluxing agent at very high temperatures to produce flux-calcined DE. This form of DE can contain cristobalite, a highly crystalline form of silica. DE is coming under increasing scrutiny because of OH&S issues associated with crystalline silica. DE use is quite labour intensive and operators must be well trained.

### Perlite

Perlite is a volcanic rock that has been treated with heat to form a fine white porous powder. It can filter to three microns. It can capture more dirt and contaminants than DE because of its porous structure, so filter cycles are

generally longer. It is also lighter than DE so less by weight is required. Exposure to the dust should be limited to avoid eye and respiratory irritations.

### Cellulose

Cellulose fibre can filter to three microns (similar to DE). When used in vacuum media filtration, it uses significantly less water for backwashing (only 10% compared to that of a typical sand filter). Compared to DE, it is cheaper and easier to use and has none of the associated OH&S issues.

### Filter media comparison table

Table 7 compares different types of filter media and shows what to consider before using or installing these.

**Table 7 – Water media comparison table**

Filter media	Features			
	Commonly used in	Filter capability	Lifetime of media	Considerations
<b>Sand</b>	Gravity, medium and high rate filter	15-20 $\mu$	5-10 years	<ul style="list-style-type: none"> <li>• Media subject to mud balling if backwash practices are poor.</li> <li>• Grading and uniformity of media is important for performance.</li> </ul>
<b>Zeolite</b>	Medium and high rate filter	3-5 $\mu$	10 years	<ul style="list-style-type: none"> <li>• Chloramines are controlled by ion exchange, so filter media needs to be regenerated yearly to maintain chloramine control</li> </ul>
<b>Glass</b>	Medium and high rate filter	> 8 $\mu$	5-10 years	<ul style="list-style-type: none"> <li>• Grading and uniformity of media is important for performance.</li> <li>• Some evidence of fewer and shorter backwash events compared to sand media.</li> </ul>

Filter media	Features			
	Commonly used in	Filter capability	Lifetime of media	Considerations
<b>DE</b>	Pre-coat filter	3-5 $\mu$	Duration of filter cycle	<ul style="list-style-type: none"> <li>Respiratory and eye protection must be worn</li> <li>Media must be collected and disposed of after each filter cycle</li> </ul>
<b>Perlite</b>	Pre-coat filter	3-5 $\mu$	Duration of filter cycle	<ul style="list-style-type: none"> <li>Respiratory and eye protection must be worn</li> <li>Media must be collected and disposed of after each filter cycle</li> </ul>
<b>Cellulose</b>	Vacuum filter	3-5 $\mu$	Duration of filter cycle	<ul style="list-style-type: none"> <li>Respiratory and eye protection recommended</li> <li>Media biodegradable.</li> </ul>

## External factors

Apart from the choice of filter and type of filter media, there are other factors related to water treatment that affect water quality and water use. These are:

- filter backwashing practices
- backwash recycling systems
- bather cleanliness
- make-up water control.

### Filter backwashing practices

For convenience and simplicity, filters are often backwashed to a schedule and for a set duration. Best practice filter operation is to backwash only when necessary. When the pressure drop across the filter exceeds the manufacturer's recommended limit (ie demand driven event), the filter should be backwashed. The pressure drop is a good indicator of the amount of sediment/solids

that the filter is removing from the pool water. A sight glass should be installed in the discharge line and the operator should immediately stop backwashing when the backwash water becomes clear.

For slow gravity sand type filters:

- allow the system to settle for 30 minutes before backwash
- use the circulation rate to trigger the backwash cycle.

For other filter types:

- use the filter pressure to determine filter backwash frequency.
- use water quality (using the sight glass) to determine the duration of the backwash cycle.

Filter backwashing uses pool water to backwash, which then needs to be topped up using fresh water. Often, backwashing is used to

dilute the pool water for chloramine and TDS control and maintain water quality or balance. If the filters don't need backwashing, it is better to bleed off concentrated pool water and add dilution water in a slower, controlled manner. This minimises the impact on pool temperatures and water balance.

Other important pool operator practices include manually removing dirt, leaves and other large solids as soon as they are detected, and cleaning the strainers regularly.

### Backwash recycling systems

Some pool owners have installed complex systems to treat and re-use the large volumes of backwash water required for filter backwashing. Costs to install a backwash water recycling system can exceed the costs of upgrading or replacing existing filters, with

comparative water savings. In addition, it is easier to avoid using water through efficient filters and good filter management than to treat and re-use backwash water.

The drinking water cost savings achieved from backwash recycling systems are often offset by the additional energy and operational costs of the backwash water treatment system. These systems are rarely cost effective as the financial payback of the system can exceed the life of the equipment.

### Bather cleanliness

Dissolved fats from natural body oils and skin lotions affect the efficiency of filters. These oils and lotions are captured within the filter and reduce the capacity of the filter media to remove other impurities. Encourage bathers to shower before entering the pool. This improves filter performance and extends the time between backwashing and filter media changes.

### Make-up water control

Water must be added to the pool for a variety of reasons. These include water losses due to backwash, evaporation, splash, bather carryout and leaks. Discharged water is automatically replaced with fresh water through the balance tank, by a float or solenoid operated valve or manually through the use of hoses and manual valves.



Minimise your water use before considering recycling systems, like this backwash water recycling system at Warringah Aquatic Centre.

### Float valves

Float valves (or ball valves) are valves controlled by a floatation device. As the level of water falls or rises in the balance tank, so does the float. The valve is opened or closed gradually in response to this. Float valves respond quickly to changes in water levels and add water to the pool at a rate proportionate to the demand. This minimises the impact of water pressure changes on the pipes, amenities and kiosks.

Float valves should be robust and of good quality. They should be installed so they are not affected by turbulence from the pool return or the make-up water. This may require protective baffles around the float. Position them for easy inspection and weekly maintenance.

### Solenoid valves

Solenoid valves are also used to control pool make-up from the balance tank. A solenoid and high and low level sensors operate the valve. Once the water level drops to the low level sensor, the valve opens fully to add water to the pool. This can result in a large and sudden impact on the water system causing water hammer, a drop in pressure and reduced flow in other areas of the aquatic centre.

Place solenoids where they can be easily inspected and weekly maintenance can be performed. The power supply must be checked regularly to ensure solenoids are working.

### Automatic valves and base flow

When there is a constant drop in the water level in the balance tank, indicating a leak, the make-up response of float and solenoid valves in the balance tank varies. For float valves, make-up is also continuous, showing up as a base flow in monitoring data.

For solenoid valves, make-up only occurs when the solenoid reaches the low level sensor. Pool make-up shows up as high flows of regular frequency and duration. Depending on the leak size, water waste can be masked by other pool operation water use in monitoring data. The use of solenoid valves makes it difficult to identify leaks.

### Manual valves and hoses

Pools often use hoses or manually operated valves for pool make-up. Valves and taps are operated by pool staff and can be accidentally left on, wasting water. It is also hard to manually match water supply with demand, which causes unnecessary water use.

### Best practice pool make-up

To better control and understand pool make-up water:

- use quality, correctly installed float valves and inspect and maintain them weekly
- do not use manually operated valves or solenoid valves for pool make-up
- do not use hoses for pool make-up
- fit a submeter to the pool make-up and set up monitoring and high use alerts.



## Chapter 16

# Evaporation

Around 70% of the heat energy lost by pools is due to water evaporating. For indoor pools, a further 27% of heat energy is lost through the ventilation system.

Evaporation rates are affected by and can be reduced by:

- controlling relative temperatures of the pool and the surrounding air
- controlling humidity of the surrounding air
- reducing pool wave and splash action
- reducing wind across the pool surface
- using pool covers
- heating, ventilation and air conditioning (HVAC) systems.

### Relative temperatures

Evaporation increases by up to 10% for every 1 °C temperature difference between the pool and the surrounding air. This water loss also contributes to a 10-15% increase in energy loss. To reduce evaporation and heat losses from the pool water, keep the air temperature in the surrounding pool hall:

- below 30 °C
- within 1 °C of the pool water temperature.

Evaporation rates are also higher at higher temperatures. It is important to ensure pool water temperatures are set as low as possible while maintaining bather comfort. The table below shows recommended pool temperatures for a range of pool activities.

**Table 8 – Recommended pool temperatures for a range of pool activities**

Recommended temperature	Activity
25-27 °C	Active swimming, training or playing water sports
27-29 °C	Passive swimming, learning to swim classes
30 °C	Hydrotherapy pools only



Shading pools helps reduce evaporation

## Humidity

Humidity is the amount of water vapour in the air. Drier air with low humidity absorbs more water and increases the evaporation rate, while moist air at higher humidity (around 70-75%) releases moisture, causing condensation.

Pool water contains a high concentration of oxidising chemicals. In indoor pools, air with high humidity causes pool water to settle on pool hall surfaces, causing corrosion. In addition, sweat on skin does not evaporate as effectively, which affects temperature regulation in bathers, causing discomfort.

A balance is needed between low humidity where excessive evaporation occurs and high humidity where corrosion and patron comfort are concerns. A relative humidity around the 50-70% range is considered a good compromise. However, the maximum and minimum humidity should be tailored to the particular climate of the indoor pool. When adjusting humidity controls, make sure you consider the occupational health and safety of your staff.

### Example

An indoor 25 m pool with eight lanes, heated at 28 °C with a pool hall temperature of 29 °C and a relative humidity of 60% will:

- lose 550 kL each year through evaporation
- waste over 300,000 kWh each year in heat energy.

These losses will cost the centre around \$10,000 a year depending on the heating system, energy sources and utility charges.

If the relative humidity dropped to 50%, these losses and costs would increase by at least 30%.

### Pool wave and splash action

In indoor wave pools, the surface area of the water exposed to the air increases. This increases the loss of water and heat to the surrounding air.

To manage wave pools more efficiently:

- reduce wave action frequency
- reduce wave action duration
- limit operation to weekends and holiday periods.

### Wind across the pool surface

Wind also increases evaporation. On windy days, water evaporated to the air is blown away from the pool and dry air replaces it. This encourages more evaporation to the dry air. For outdoor pools, a 10 km breeze across the surface of a pool can increase water and heat loss two to three times. Under normal conditions, an outdoor Olympic pool can lose six kilolitres of water (9,500 kWh) a day. Moderate winds can more than double these losses.

When protecting a pool from wind, consider:

- the direction of southerly and westerly winds
- installing wind breaks next to the pool
- installing pool covers.

## Pool covers

A pool cover limits the exposure of the pool surface to the surrounding air by providing a physical barrier between the pool surface and the atmosphere. This reduces the water, chemical and heat loss from the pool caused by evaporation.

After optimising water and air temperatures and reducing wind, the next most important water and energy savings measure is to use a pool cover when the pool is not in use. Properly designed pool covers can reduce:

- water losses by 30-50%
- heat losses by 70-90%
- heating, ventilation and air conditioning (HVAC) running costs
- the effect of condensation on the building structure, fabric and fittings.

High quality pool covers are required due to the varying Australian climate. Table 9 shows common advantages and disadvantages of the major pool cover types. Ideally, the pool cover should be:

- Smart WaterMark approved
- easy to use and store
- easy to maintain
- durable.

**Table 9 – Advantages and disadvantages of pool cover types**

Material	Advantages	Disadvantages
Slatted	<ul style="list-style-type: none"> <li>• Durable</li> <li>• Long lasting</li> <li>• Fully automated</li> </ul>	<ul style="list-style-type: none"> <li>• Expensive</li> </ul>
Solar	<ul style="list-style-type: none"> <li>• Very light</li> <li>• Inexpensive</li> <li>• Operated by a battery operated winch</li> </ul>	<ul style="list-style-type: none"> <li>• Delicate</li> <li>• Tears easily</li> </ul>
Insulated vinyl	<ul style="list-style-type: none"> <li>• Durable</li> <li>• Long lasting</li> <li>• Inexpensive</li> <li>• Operated by a battery operated winch</li> </ul>	<ul style="list-style-type: none"> <li>• Heavy</li> </ul>

To improve the use and effectiveness of pool covers consider:

- installing a system to automatically operate the pool cover
- linking pools to a monitoring system to measure energy and water savings.



Use a pool cover when the pool isn't being used, to limit evaporation and heat loss

## Heating, ventilation and air conditioning (HVAC) systems

Heat energy and moisture is lost through the pool hall HVAC system and can be recovered by transferring it to the incoming fresh air. This transfer reduces energy and water loss from the pool hall and also makes it easier to control temperature and humidity in indoor pools.

Thermal wheels and cross-flow heat exchangers can reduce the energy needed to heat incoming fresh air by up to 30%. These can recover:

- latent heat – embedded in the warm moisture and given up when it condenses.
- sensible heat – heat energy carried in air molecules.

It is important to design HVAC systems for the specific conditions of your aquatic centre.

## Useful references:

*Australian Standard AS 3780-1994 The storage and handling of corrosive substances*

*Australian Standard AS 4326-2008 The storage and handling of oxidizing agents*

Department of the Environment, Transport and the Regions, 1998. *Good Practice Guide 228. Water related energy savings – a guide for owners and managers of sports and leisure centres*. Environmental Technology Best Practice Programme, Oxfordshire, UK

South East Water, *Water wastage takes a dive*, Aquabiz, Issue 7, March 2010, p 8-9, [http://www.sewl.com.au/SiteCollectionDocuments/Aquabiz/Aquabiz\\_Version\\_7-March\\_2010.pdf](http://www.sewl.com.au/SiteCollectionDocuments/Aquabiz/Aquabiz_Version_7-March_2010.pdf)

The Carbon Trust. 2006. *Sports and Leisure. Introducing energy saving for business*. The Carbon Trust, London, UK

WorkCover New South Wales, *Storage and handling of dangerous goods, code of practice*. [http://www.workcover.nsw.gov.au/formspublications/publications/Documents/storage\\_handling\\_dangerous\\_goods\\_code\\_of\\_practice\\_1354.pdf](http://www.workcover.nsw.gov.au/formspublications/publications/Documents/storage_handling_dangerous_goods_code_of_practice_1354.pdf)





## Part 3

### Aquatic centre efficiency

Part 3 of *Best practice guidelines for water management in aquatic leisure centres* is aimed at facility managers and aquatic centre managers. It describes practical steps to reduce water and energy use in amenities, kitchens, water features and gardens. It also has recommendations for renovating or building a new aquatic centre.

## Introduction

After fixing leaks and addressing water use in your swimming pool, you should look at water use in other areas of your centre. Figure 17 (seen previously) shows the water use breakdown of a typical aquatic centre. Forty-two per cent of water is used in areas other than swimming pools and leaks. Thirty-five per cent of water is used in amenities and includes water used for backwashing filters. Wasting water in amenities and kitchens also wastes the energy used to heat the water.

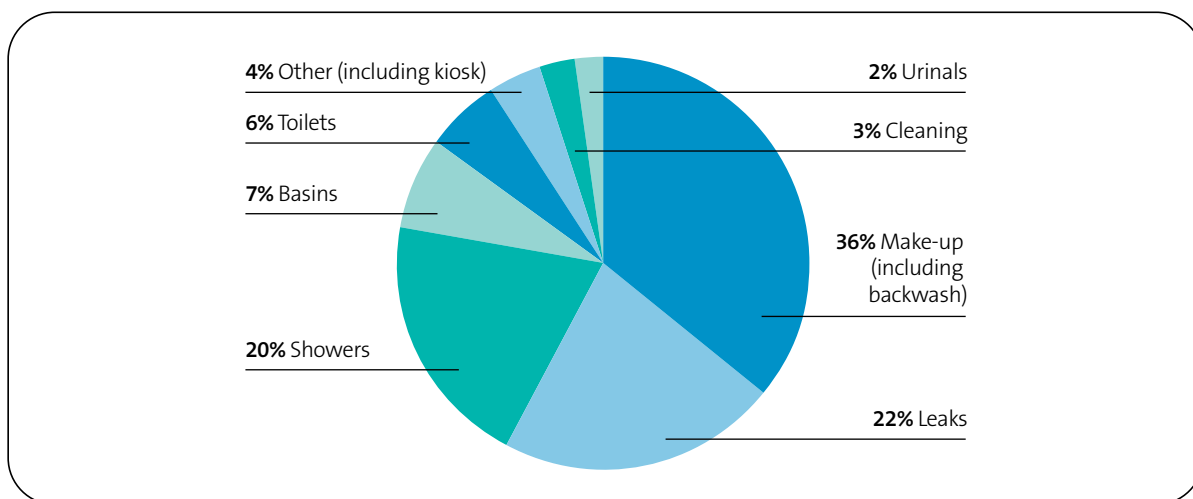

Figure 17 – Water use breakdown of a typical aquatic centre shows 42% of water is used in areas other than swimming pools and leaks.

## Chapter 17

# Amenities

Amenities include showers, toilets, basin taps and urinals and account for 35% of water use in aquatic centres. This means there are great opportunities to save water with low cost, easy to implement measures, with a short payback.

Amenities are used frequently in public facilities like aquatic centres. Reducing water use in amenities means for each individual use, a small saving can be made, adding up to large overall savings. Figure 18 shows a breakdown of water use in amenities. By improving the water efficiency of amenities, you can cut water use by about 25%.

### Showers

Showers make up 57% of water use in amenities. Hot water for showers makes up six per cent of overall energy use.

Bathers should have pre-swim showers. Pre-swim showers reduce dirt, oils and sweat entering the pool on the bather. Showers should only be used after pool use to rinse off chlorine and other chemicals. Discourage patrons from using aquatic centre showers for their daily domestic showering.

By addressing water use in showers, both water and energy savings can be made. Here are a number of tips to help you reduce water and energy use in your showers.

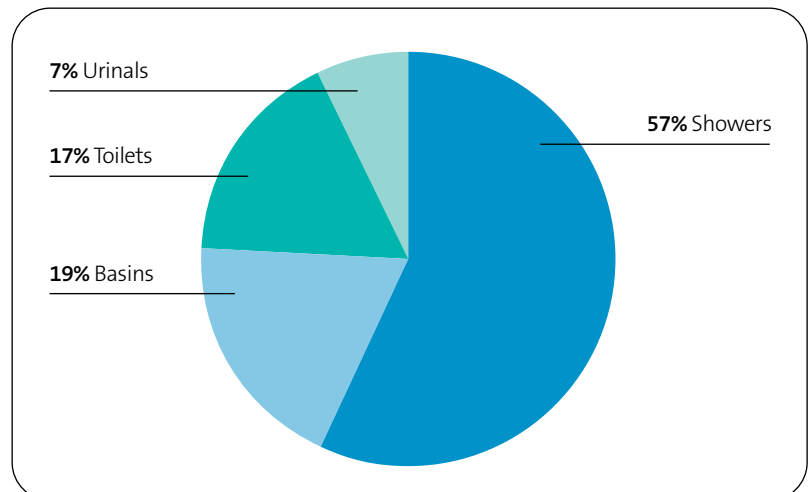

Figure 18 – Breakdown of water use in amenities. Slow showers use the most water



Install vandal proof housings over basin tap flow restrictors to prevent theft



### Retrofit or replace showerheads

Earlier showerheads typically have a flow of 15-20 L/min, especially in older facilities. By installing flow restrictors, an aquatic centre can reduce the flow in showers to less than nine litres a minute.

Early showerheads should be replaced with WELS 3 star rated showerheads that use 7.5-9 L/min. More information on WELS star ratings can be found at the end of this chapter.

### Install vandal proof fixtures

The high use and availability of showers and taps in amenities makes them susceptible to vandalism and increased wear and tear. This means they break more often, causing leaks. Plumbing fixtures should be inspected weekly to identify and fix leaks.

Consider installing vandal proof showerheads and push button taps to reduce the frequency of breaks and vandalism. Basin tap flow regulators can easily be fitted with vandal proof housings to prevent theft.

### Install timed showers

Many aquatic centres are installing push button timer showers to keep showers short. Push button timer showers work by limiting the duration of a shower. After the button is pressed, water flows for a set period of time, usually one to one and a half minutes. After this, patrons must press the button again to continue their shower.

Showers can also be set up so a patron is required to push and hold a button down to operate the shower. However, this option may make having a shower difficult for elderly patrons.

If you do install push button timed showers, consider that some patrons do not like having warm showers. To overcome this, install at least one cold-water only shower to accommodate all patrons and avoid complaints.

### Charge for showers

If patrons are paying for showers, they are more likely to be water wise. Some aquatic centres charge patrons to use showers in amenities. Charging for timed showers can also be used as a community education tool and a revenue generator to fund water efficiency measures.

Some patrons may not have a pre-swim shower if they have to pay for it. Pre-swim showers help reduce dirt, oils and sweat entering the pool with the bather. To encourage pre-swim showering when charging for showers, it may be helpful to provide one free shower near the exit of change rooms.

## Case study

### Showers at Warringah Aquatic Centre

Warringah Aquatic Centre now charges 20 cents for one minute timed showers. To limit patron complaints, they coupled the introduction of timed showers with a community education campaign. Warringah Aquatic Centre committed to reinvesting revenue raised from showers into further sustainability projects. Patrons are more willing to accept paying for showers, because Warringah Aquatic Centre demonstrated commitment to water efficiency.





INSERT COINS FOR OPERATION  
ACCUMULATES  
VALUE FOR  
CONTINUOUS USE  
ASBERFIELD  
INDUSTRIES  
P.O. BOX 10000  
MILWAUKEE, WI 53210

4

INSERT COINS FOR OPERATION  
ACCUMULATES  
VALUE FOR  
CONTINUOUS USE  
ASBERFIELD  
INDUSTRIES  
P.O. BOX 10000  
MILWAUKEE, WI 53210

5

INSERT COINS FOR OPERATION  
ACCUMULATES  
VALUE FOR  
CONTINUOUS USE  
ASBERFIELD  
INDUSTRIES  
P.O. BOX 10000  
MILWAUKEE, WI 53210

6

## Basin taps

In aquatic centres, hand basins make up seven per cent of water use in amenities, and have flow rates of up to 20 L/minute. Heating hot water for use in hand basins accounts for 1.2% of overall energy used.



Install sensor activated or push button taps to limit how long taps run for and help stop people leaving taps on

## Retrofit or replace taps

Flow can easily be restricted to six litres a minute or less by retrofitting flow regulators or replacing taps. Fixtures should have a minimum WELS 3 star rating. WELS 5 or 6 star rated taps are available and recommended for hand basins. Hand basin taps and pressure-compensating aerators with flow rates down to as low as 1.7 L/min are available.

## Install push button taps

Push button taps in hand basins operate the same way as they do in showers (see ‘timed showers’). They stop water loss from patrons accidentally leaving the tap on and limit the duration to around 10 seconds.

## Install sensor activated taps

Sensor activated taps can also limit the duration of hand washing and can improve washroom hygiene. Sensor taps activate when a sensor detects movement, usually by hands in front of the sensor or a person standing under a sensor. When an object is detected, water flows until the object is removed. There is no need for people to touch taps after they have washed their hands.

Sensor taps require regular inspection to ensure the sensor units work well, cut off when not required and are not falsely triggered by bathroom traffic or light movement. If sensors are not adjusted and maintained properly, they can use more water than standard taps.

## Toilets

Toilets make up to 17% of water use in amenities. Replacing just one 11 L single flush toilet with a WELS 5 star rated 4.5/3 L dual flush toilet can save 140 kL of water a year and \$484 in water and wastewater costs (2010-11 pricing).

### Retrofit or replace toilets

The amount of water used in older single flush toilets can be reduced from 11 L to nine litres a flush by installing a cistern weight or adjusting the float down. Reducing the flush in older single flush toilets to less than nine litres a flush is not recommended because old toilet pans need enough water to properly flush the pan and prevent pipes from being blocked. Replacing older single flush toilets with low-flow dual flush toilets is the best option.

If you are buying new toilets, they should have a minimum WELS 3 star rating. WELS 5 or 6 star rated toilets are available and recommended. If you are using very low flush toilets (such as 4.5/3 L dual flush models), consider how steeply the pipes drain. Pipes with a low gradient may become clogged with very low water flows. Check with the toilet manufacturer for installation advice.

## Vacuum toilets

Vacuum toilets can also be used for amenities connected directly to wastewater systems. Water use is about half a litre each flush.

A vacuum system needs a pump to create the vacuum. One pump can service a number of toilets and can be located in a different room or in the ceiling space.

Vacuum toilets look similar to traditional flushing toilets and installation costs are comparable.

## Flusherette systems

Where your centre uses a flusherette tank and individual toilet flush valves, make sure the valves are properly tuned and maintained to limit the flush volume to less than 5.5 litres. The pressure in the flusherette system piping varies depending on the distance from the tank. Adjust and maintain individual flush valves to account for the pressure difference.

Set the flush duration to around three seconds, as this is usually a five to six litre flush (dependent on supply pressure). Flush valves should shut-off completely, with no excess water dribble.



Replace existing single flush toilets with low-flow dual flush toilets

## Urinals

In aquatic centres, urinals make up seven per cent of water use in amenities. There are various types of urinals. Cyclic flushing or automatic flush urinals waste a lot of water and should be immediately replaced with sensor or manual flushing systems. When installing urinal sensor flush systems, make sure manual shut-off valves are included, so malfunction does not cause continuous flushing.

Urinal sensors can waste water if they malfunction, or if they are incorrectly set to detect

normal bathroom traffic. Inspect and adjust sensors, so they only trigger a flush when someone stands in front of or on the raised platform or has used the urinal.

Replace batteries in urinal sensors regularly, as flat batteries can lead to constant flushing. Consider replacing battery-powered sensors with those that require connection to an electrical supply.

Routinely maintain and adjust sensors to function correctly and maintain their water efficiency. Use highly efficient urinals with a WELS rating of 5 or 6 stars, or consider

waterless urinals when replacing amenities or fitting out new buildings.

Ensure all plumbing and building work meets the relevant Australian standard and code to avoid future operational and maintenance problems.

To know more, refer to Sydney Water fact sheet *Waterless urinals*, which describes the different types of waterless urinals available and how to install them successfully. You can obtain a copy of *Waterless urinals* from your Business Customer Services representative or from [sydneywater.com.au](http://sydneywater.com.au)



Replace or retrofit conventional urinals with low-flow urinals and regularly maintain and adjust flush valves and sensors

## Pressure and flow problems

Many aquatic centres are concerned about patron comfort when replacing showerheads with low-flow alternatives or retrofitting them with in-line flow restrictors. Older styles of low-flow showerheads do not compensate for pressure differences with reduced flows, resulting in patrons complaining about lack of water pressure.

Loss of water pressure in plumbing fixtures usually occurs in fixtures towards the end of a series or bank of showers. To maintain water pressure evenly in the showers, install constant flow regulators in all fixtures at the same time. This ensures every fixture has exactly the same flow rate. This is called a balanced system.

Constant flow regulators include a rubber O-ring that expands and contracts as the pressures rise and fall, providing constant and accurate flow through the fixture.

### Thermostatic mixing valves

You may not be able to restrict some fixtures to less than four to six litres a minute. This is because they may have thermostatic mixing valves (TMVs), also known as temperature moderating valves. TMVs require flows of between six and 20 litres a minute.

TMVs mix hot and cold water together to achieve a constant temperature of water from fixtures. Reducing flows through TMVs to below six litres a minute could scald patrons with hot water or prevent any flow of hot water to the basin or shower. The hot and cold water may have different pressures and the water with the higher pressure will always dominate.

Additionally, some systems are designed for high flows to keep warm water circulating. If the warm water flow is restricted, it could lead to a build up of bacteria in 'dead legs' of piping. Staff and patrons may need to run a tap for a long period before the desired water temperature is achieved.



Install flow restrictors on all non-regulated fixtures and repair or replace them as part of an active maintenance program

### Staff amenities

Maintaining staff-only toilets and taps can be a low priority for maintenance staff, because they are not subject to public scrutiny. Leaks waste money wherever they are.

If you don't fix leaks and inefficient equipment in staff areas, it shows a lack of commitment to water efficiency.

Sydney Water's *Save It* stickers are a good way to encourage staff to report leaks to plumbing or maintenance staff. Printed stickers are available for business customers and artwork is available at [sydneywater.com.au](http://sydneywater.com.au)

### Maintaining amenities

An active maintenance program is essential to detect and repair leaks and broken amenities. Good maintenance is often the cheapest and most effective way to be water efficient. Develop an inspection timetable and make sure staff know how to report leaks and other problems.

Perform these key actions for amenities maintenance:

- Ensure toilets, urinals, taps and showers are regularly inspected for leaks.
- Replace rubber cistern seals and tap washers at least every two years to avoid leaks.
- Check that urinal sensors work correctly and do not trigger a flush when customers are only using basins or entering toilet cubicles.
- Check that solenoid valves on urinal cisterns are not leaking.
- Install flow restrictors on all non-regulated taps.

## WELS ratings explained

WELS is the Water Efficient Labelling and Standards program. WELS gives products a star rating based on their water efficiency.

WELS ratings are available for taps, toilets, showers and urinals. The ratings are taken from *AS/NZS 6400:2005 amendment 3 2006*.

**Table 10 – WELS ratings for showers**

Rating	Specification (L/min)
<b>0 Star</b>	> 16
<b>1 Star</b>	> 12 and =< 16
<b>2 Star</b>	> 9.0 and =< 12
<b>3 Star</b>	> 7.5 and =< 9.0 <sup>a</sup>
<b>4 Star</b>	> 6.0 and =< 7.5 <sup>a</sup>
<b>5 Star</b>	> 4.5 and =< 6.0 <sup>a</sup>
<b>6 Star</b>	> 4.5 and =< 6.0 and fitted with bonus features (eg automatic shut-off) <sup>a</sup>

<sup>a</sup> subject to finalising industry force of spray test

**Table 11 – WELS ratings for tapware**

Rating	Specification (L/min)
<b>0 Star</b>	> 16
<b>1 Star</b>	> 12 and =< 16
<b>2 Star</b>	> 9.0 and =< 12
<b>3 Star</b>	> 7.5 and =< 9
<b>4 Star</b>	> 6 and =< 7.5
<b>5 Star</b>	> 4.5 and =< 6.0
<b>6 Star</b>	=< 4.5

Table 12 – WELS ratings for toilets

Rating	Full	Half	Average (L/flush)
<b>0 Star</b>	N/A	N/A	N/A
<b>1 Star</b>	=< 9.5	=< 4.5	=< 5.5
<b>2 Star</b>	< 9.5	=< 4.5	=< 4.5
<b>3 Star</b>	=< 6.5	=< 3.5	=< 4.0
<b>4 Star</b>	=< 4.7	=< 3.2	=< 3.5
<b>5 Star</b>	=< 4.7	N/A	=< 3.0
<b>6 Star</b>	=< 4.7	N/A	=< 2.5

Table 13 – WELS ratings for urinals

Rating	Specification (L/single stall or L/600 mm of continuous length)
<b>0 Star</b>	> 2.5 serving a single stall or 4.0 for two stalls
<b>1 Star</b>	=< 4.0 serving two stalls or equivalent continuous width <sup>a</sup>
<b>2 Star</b>	=< 2.5 serving single stalls or equivalent continuous width <sup>a</sup>
<b>3 Star</b>	=< 2.0 serving single stalls or equivalent continuous width <sup>a</sup>
<b>4 Star</b>	=< 1.5 serving single stalls or equivalent continuous width <sup>a</sup>
<b>5 Star</b>	=< 1.0 serving single stall stalls or equivalent continuous width <sup>a</sup>
<b>6 Star</b>	=< 1.0 serving single stall or equivalent continuous width <sup>b</sup>

<sup>a</sup> must be fitted with demand-driven or smart-demand operation

<sup>b</sup> must be fitted with demand-driven or smart-demand operation with a urine sensing device



## Chapter 18

# Kitchens and kiosks

The main areas of water use in kiosks are:

- basins and sinks
- hot water
- food preparation, including thawing food
- pre-rinse spray valves
- dishwashers and glasswashers
- icemakers
- cleaning.

Even in busy kiosks it is important to report leaks and undertake regular maintenance. One leaking hose in a kitchen audited by Sydney Water wasted a kilolitre a day.

### Basins and sinks

Install separate sinks for hand washing and food preparation. Basins used for hand washing should have flow restrictors on taps, as described in the previous chapter. If taps are only used to fill pots and pans and to fill sinks for dishwashing, flow can be maintained at nine litres a minute. Use an efficient pre-rinse spray valve to rinse plates rather than a kitchen tap. Regularly inspect kitchen taps for leaks.

### Hot water

If the hot water system supplying your kitchen or kiosk is not located close to the kitchen, install a separate hot water system closer to your kitchen, or install a 'ring main' or thermal loop system and insulate the hot water supply line.

One aquatic centre kitchen was wasting 52 L of water every time they turned on the hot tap. Because their hot water system was located on the other side of the centre and the supply line was not insulated, it took a long time for the hot water to reach the kitchen.

### Food preparation

Do not use running water to thaw frozen food. This can use up to six kilolitres of water a day, and can allow food poisoning organisms to grow.

To save water and reduce health risks, thaw food by:

- placing frozen food in a refrigerator the night before using it. This enables the food to thaw while remaining cool, retaining good texture and remaining free of contamination from bacteria and toxins

- using a microwave oven. Only use this method of thawing food if you intend to cook meat immediately, as the microwave can start the cooking process.

Food safety standards in New South Wales require kitchens to minimise the amount of time foods (such as meat) are kept between 5°C and 60°C. Defrosting food under running water is likely to put food into this temperature zone.

### Pre-rinse spray valves

Pre-rinse spray valves are used to remove food scraps and grease from dishes before they go into the dishwasher. They are used instead of rinsing dishes under running taps.

Standard pre-rinse spray valves use a lot of water. A Sydney Water study estimated that pre-rinse spray valves in Sydney use 5,900 ML of water every year. This is similar to supplying about 23,000 houses with water for a year.

Older pre-rinse spray valves have a spray nozzle similar to a showerhead and use between 10 L and 15 L of water a minute. They don't have a strong jet of water and are slow to clean. Efficient valves use only six litres of water a minute – 40% less than older models.

Image left – Use an efficient pre-rinse spray valve to rinse plates before they are loaded into the dishwasher

Smart Rinse valves have a nozzle with a high pressure, blade-shaped spray. The high water pressure and cutting action means that dishes are cleaned quickly and effectively. Smart Rinse valves generally deliver water between 40°C and 60°C. This means 60% of cost savings are from reduced energy use.

Inspect all pre-rinse spray valves regularly and replace them if the fittings are worn. Worn nozzles reduce pressure and spray angle, waste water and increase washing time. Check with your supplier to ensure you are using the right design of spray rinse valve for your job.

### Ice making machines

Ice making machines can use a lot of water and energy. Make sure your machine is not oversized or set to make more ice than needed. Air-cooled ice machines are far more water efficient than water-cooled models.

Water-cooled machines may use less energy. If you do choose a water-cooled machine, make sure it uses an evaporative condenser to cool, and not a 'one-pass' system. One-pass systems are very water intensive.

### Cleaning kitchens and kiosks

These recommendations can cut the amount of water used for kitchen cleaning:

- Use a sink strainer or dry waste arrestor to trap food scraps before disposal.
- Scrape food off plates before using a pre-rinse spray valve.
- Sweep and mop the floor instead of hosing it down with water.

### Sink-to-sewer waste disposal units

Sydney Water does not allow sink-to-sewer disposal units (also called in-sink food waste disposal units or garbage grinders) in non-domestic buildings. For more information, see Part 5, Managing your wastewater.



Scrape food scraps from plates and cooking equipment into the bin before rinsing them in the sink



Sweep and mop kitchen floors instead of hosing them

## Chapter 19

# Cleaning your aquatic centre

The floor surface of pool halls, public areas and amenities are either tiles or concrete. Generally, water is used to clean and wash these surfaces. Most cleaners have little training in using water efficiently when cleaning. This contributes to high water use.

Cleaning large surface areas is very labour intensive. Without the cooperation of staff and cleaners, lots of water can be wasted. To minimise water used in cleaning, follow these steps:

- Monitor and analyse water use during cleaning periods.
- Inspect or audit cleaning practices.
- Identify areas that need improvement.
- Educate and train staff on how to use water efficiently when cleaning.
- Set targets and responsibilities for water use by cleaners.
- Issue policy instructions banning the use of fire hoses and open hoses.
- Provide regular monthly feedback on performance and progress against targets.
- Use incentives and recognise cleaning staff for good work.



If hoses must be used for cleaning, make sure they have water efficient trigger nozzles

Develop a cleaning schedule together with staff. This should include clear roles and instructions for staff and where, when and how often cleaning equipment such as hoses should be used.

These steps will help change the cleaning behaviour of contractors and staff, making them responsible for efficient use of water while cleaning. Review these regularly to ensure continual improvement.

In Sydney, aquatic centre staff often use large open-ended hoses instead of a broom

to sweep or wash away dirt and debris. This wastes a lot of water. If water must be used to clean hard surfaces:

- use commercial high pressure water efficient trigger nozzles on hoses
- sweep and mop dirty areas instead of hosing
- use a commercial floor scrubber that recycles the cleaning water
- use high pressure water efficient water brooms to combine sweeping and washing.

## Chapter 20

# Water features

Water features can be a focal point of architecture or landscaping. Well designed and maintained water features use little water.

Leaks, excessive splash, evaporation and wind drift increase the amount of water used by water features. Good design, monitoring and regular maintenance are essential to ensure your water features do not waste water.

### Water feature design

Use these tips to maximise water efficiency in water features:

- Individually submeter supply lines to water features.
- Install fountains behind windbreaks or in areas sheltered from wind to reduce wind drift and evaporation.
- If you plan to use trees as windbreaks, choose their location and their species to reduce the number of leaves that fall into the water feature.
- Use shading and lighter coloured stones in water features to limit evaporation.
- Use rainwater and stormwater in water features as an alternative to drinking water.

### Water feature maintenance

Good maintenance is one of the easiest ways to save costs:

- Read water meters regularly and record water use to identify leaks and excessive water use.
- Instruct your water treatment contractor to telephone you to discuss any water waste or leaks detected in their monthly inspections. Ask them to highlight leaks in their monthly reports.
- Regularly check level sensors and float valves. These are often the cause of waste. Water features with lots of splashing can sometimes make poorly designed float valves in the balance tank bob up and down and cause top-up waste.

- Install a wind sensor that can automatically turn off water features that are prone to wind drift. On gusty days, manually turn off the fountain, as wind sensors don't always work well in these conditions.
- Use a gate valve in preference to a ball valve on the top-up line and set it so that the feature tops up slowly. If a problem causes the top-up to run continuously, less water will be wasted before the problem is detected and fixed.

Table 14 shows the water use for a range of water feature types.



Avoid water features with excessive splashing or spray, as these use more water

**Table 14 – Water use for a range of water feature types**

Type of water feature	Water use
Small, well designed and maintained	Less than 1 kL/day to 3 kL/day
Poor design and construction, no maintenance or monitoring	Up to 200 kL/day
Poorly maintained with regular dumping and/or overflow of water	Sydney Water has seen examples where water use has increased by up to five times

### Cleaning water features

Reduce cleaning frequency and use biocides to stop microbial growth in the water. Ensure chemicals chosen cannot corrode the water feature's plumbing.

Bromine is often used to stop microbial growth in water features because it has lower odour than chlorine. Bromine corrodes brass and copper pipes so PVC piping is recommended. PVC is also less expensive than copper.

Detergents or foaming agents can damage rubber seals and cause leaks. They can also create a film on water level sensors, which causes overflows. Anti-foaming agents are effective if applied quickly. If foam is left to build up, all the water must be dumped and replaced.



Locate water features away from windy and sunny areas to limit evaporation

## Chapter 21

# Gardens and sports fields

You can save water and improve the appearance of gardens and sports fields by improving soil and making the best of irrigation.

The amount of water you need to use in gardens depends on the:

- soil type and quality
- plant or turf type
- location
- garden size.

Good soils capture rain better, reducing how much you need to irrigate. Different soils have different water holding capacities.

### Improving soil

The most reliable and cost effective way to improve soil is to improve topsoil. Studies by Sydney Water found some sports fields in Sydney were not irrigated during the drought and were still well grassed because they had good topsoil depth.

To survive on rainwater alone, sports fields in eastern Sydney need at least 170 mm of topsoil, and in western Sydney they need at least 200 mm of topsoil.

You can also improve the soil's ability to hold water. In sandy soil, add manure or small amounts of clay to bind the sand particles. Clay soil can be improved by adding manures or composts. This helps to separate the fine clay particles and allows water to infiltrate more quickly.

### Different soil profiles



Clay



Compacted



Water repellent



Good soil profile

Image right – Using mulch around plants helps the soil retain water by reducing evaporation



### Maintaining your soil

Regularly aerate soil and reduce compaction to maintain good quality turf. Clay loam soil typically needs more frequent aeration than sandier soil to avoid compaction. Sandy soil is more prone to compaction if it contains a lot of organic matter.

Aeration can be achieved by extracting cores of soil. Ensure that aeration extends below the depth of compaction.

### Mulching gardens

Mulching around plants helps to retain water in the soil. Good mulch adds organic matter, stabilises soil temperatures and reduces evaporation from the soil surface by up to 70%. Mulch can also inhibit weed growth. Poor mulches can cause water repellence. To avoid this, make sure mulch is composted before it is applied.

For best results, apply mulch between 50–70 mm deep to insulate roots from heat and suppress weed growth. Avoid fine textured mulches because they tend to remain wet for longer and weeds can become established within the mulch.

### Efficient watering

For gardens, water the base of plants and not the leaves (except ferns). This provides water directly to the roots where it is needed most and reduces evaporation and leaf burn. You can also save water by irrigating early in the morning or late in the evening.

A good landscape/irrigation assessment will recommend a site-specific irrigation management plan. This will improve irrigation efficiency, reduce the risk of waterlogging, cut over-watering and avoid unnecessary water charges.

Water Wise Rules affect how you can use water on landscaped areas.

### Irrigation systems

Professionally installed irrigation systems with soil moisture sensors ensure water is applied evenly at a rate that matches the soil's absorption capacity and in sufficient amount to fill the soil profile.

Automatic irrigation systems are most effective if adequately calibrated to an appropriate irrigation schedule. If you do use an automatic system, make sure it has rain and soil moisture sensors, so that water is only applied when needed. All systems must be inspected regularly to make sure that sprinkler heads and timers are working properly and not wasting water.



Inspect irrigation systems regularly to make sure sprinkler heads and timers are working properly

## Plant selection and maintenance

The types of plants and turf you select will affect how frequently you need to water. Extra time spent selecting plants for your landscaping will be repaid in better survival and growth rates, and a more attractive site for people to visit.

Consider the following points when selecting plants:

- Group plants together that have similar water requirements.
- Match the plant to the conditions in which they will be living. Do not use plants native to rainforests or creeks if you want them to grow next to surfaces that reflect heat and light, receive full sun, or next to vents that expel hot air.

For information on selecting the right plants for your area and soil type, visit the Sydney Water website [sydneywater.com.au](http://sydneywater.com.au) or contact your local council.

## Selecting turf

Make sure that good quality topsoil is 170-200 mm deep so that deep-rooted turf species, such as Kikuyu, Couch and Buffalo, can draw on deeper water reserves during droughts. Buffalo grasses (such as Palmetto) are slow growing and do not need mowing as often as other lawn grasses.

Don't mow your lawn too short. Leave grass at least

20 mm high so that the roots are able to grow deep into the soil profiles and make use of the stored water. Maintain this length by cutting only the top third of the leaf area. In dry conditions, leave the clippings on the lawn to keep moisture in the ground and cycle nutrients back into the soil.



Select plants that are native to your area and can handle the specific environmental conditions of your centre



Water resilient plants are a great way to save water in your garden and still have it looking great

## Chapter 22

# New and renovated aquatic centres

Resource efficiency starts with good design. Making your aquatic centre sustainable will save dollars later.

Make sure water and energy efficiency is included in the initial design brief to architects, designers and developers.

Sustainability can affect almost every aspect of building design and your design consultants, builders and subcontractors need to understand your requirements.

### Water efficiency

Specify water efficient equipment for all parts of your new centre. This includes taps, toilets and showers, as well as big items such as swimming pool filters and pool covers.

Install submeters in key locations in your centre and data cables to transport information to a central location.

Think about where you can catch rainwater and place rainwater tanks. What about stormwater harvesting systems? Is it possible to re-use greywater? Installing plumbing for alternative water systems is generally easier and cheaper to do during building than afterwards.

Consider installing an automatic pool cover system, with pool cover storage built

into pool deck design. This will reduce the physical labour required to use pool covers and make their use more likely.

### Energy efficiency

Specify energy efficient equipment for all parts of your new centre. This includes heating and air conditioning, lights, lighting displays, fridges, freezers, vending machines and cooking equipment.

A well-designed centre can take advantage of smaller and more efficient cooling and heating systems. Make sure your architect thinks about heating and cooling from the start, so centre design and layout can support efficient systems. Alternative cooling systems can use less energy and increase the amount of fresh air you can vent into the centre.

Install solar hot water systems and photovoltaic cells on your roof to generate your own electricity.

Use environmentally friendly and sustainable building materials wherever you can. Use locally made building materials that have low embedded energy and good thermal mass – such as clay bricks – instead of energy

intensive materials that transmit a lot of heat – such as aluminium.

Make sure your centre is facing the best direction to maximise daylight and reduce the amount of heat gained on hot days. Design features like louvres, large eaves and high performance glass facades can cut solar heat gain. High windows and double glazed windows can let in light with little heat. The cooler your centre, the smaller and cheaper your cooling systems can be. This will save water, energy and money over the entire life of your centre.

### Landscaping

Reduce the amount of hard outside surfaces with features such as gardens, rooftop gardens and absorbent paving. This will reduce stormwater run-off and improve its quality. It will also reduce your centre's impact on the surrounding environment, and improve the quality of any stormwater you capture and re-use.

What kinds of landscaping are you going to use? Can it handle the extremes of hot, cold and dry weather likely to be experienced at your centre? Are the plants

you choose native to your local area, and how are you planning to preserve any native vegetation on your site? Landscaped areas and green roofs can reduce the amount of heat reflected around your site and reduce heat loads on your centre.

### Waste

Reduce the amount of construction waste generated. Can you design your new centre so you incorporate elements of the existing centre and recycle building materials? Can you design your centre to reduce the amount of excavation needed on-site? This will reduce the amount of spoil generated and make environmental management of the building site easier.

Incorporate waste recycling systems into the design of your centre. Paper, metal, plastic and glass collection will be easier, safer and more effective if clean and safe collection and storage facilities are available. Perhaps you could also incorporate a compost system or worm farm to recycle organic waste.

### Site access

Think about site access. Is your centre easy to get to by public transport, by foot and by bike, as well as by car? Is access safe and easy for all patrons and staff?

Is there easy access to large plant and equipment for maintenance and repair?

### KPIs for new centre performance

It may be useful to set specific KPIs when renovating or designing a new centre.

For example, you may specify a 15% reduction in water and energy use compared to your unrenovated centre, or specify that the centre must meet best practice benchmarks for water and energy use per square metre, bather or patron.

### Useful documents

*AS//NZS 6400:2505 amendment 3 2006, Water Efficient Products – Rating and Labelling*







## Part 4

### Alternative water sources

Part 4 of *Best practice guidelines for water management in aquatic leisure centres* is aimed at council and aquatic centre sustainability officers and facility managers. It includes information on using alternative water sources in aquatic centres. Sydney Water recommends you minimise your demand for water (using the steps in Chapter 5), before you consider alternative water sources.

## Introduction

It is not always necessary to use drinking water. Depending on the end use of water and the quality required, alternative water sources may be used. This could be rainwater, wastewater, bore water or recycled water. Using alternative water sources can be complex and costly. Figure 19 shows options for water efficiency in order from simplest and most cost effective to more complex.

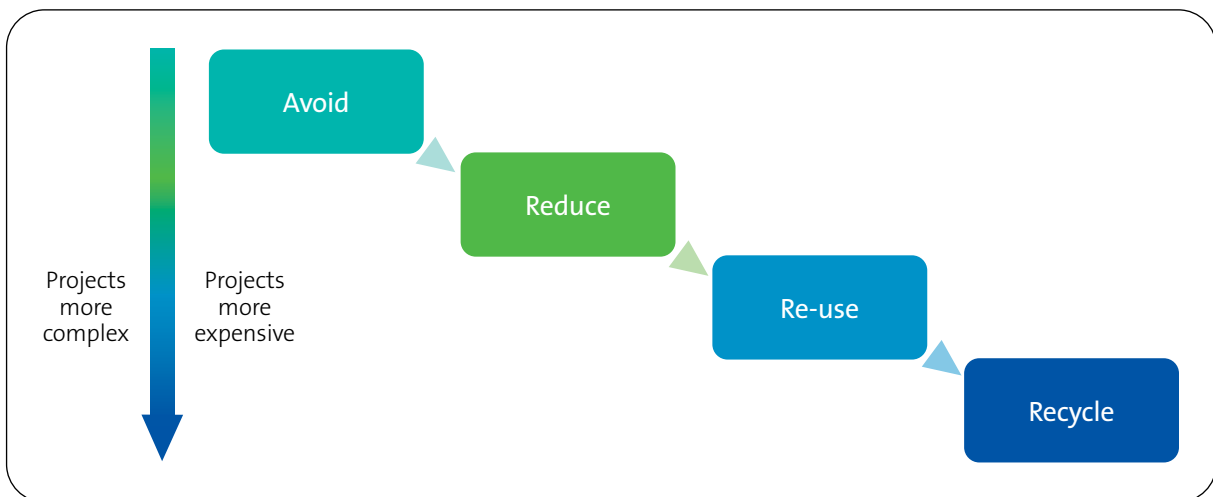

Figure 19 – Options for water efficiency projects

Consider options for water efficiency in the following order:

- Avoid using drinking water where possible. For example, instead of using a hose to clean path areas, use a broom.
- Reduce the amount of water used in amenities. For example, use efficient low-flow showers (refer to Chapter 17).
- Re-use water if you cannot reduce the amount of water being used in a process. Try to use water more than once by treating and re-using filter backwash water, harvesting rainwater or using bore water.
- Recycle water by treating and using wastewater.

The following chapters outline potential uses for alternative water sources in aquatic centres. Risk management guidelines for aquatic centres using alternative water sources and a risk assessment matrix can be found in Appendix 1.

## Chapter 23

# Rainwater

Rainwater harvesting provides a readily available alternative water source. Using rainwater can reduce demand for mains drinking water and reduce stormwater discharges from your site.

Rainwater collected from roofs generally has low levels of pollutants. This makes any required treatment simple and inexpensive, and increases the opportunities for re-use.

The bigger and cleaner your roof catchment area, the more likely you will be able to implement an effective rainwater re-use scheme.

### Using rainwater

Harvested rainwater can be used for:

- pool make-up
- toilet flushing
- washing machines
- water features
- garden irrigation
- outdoor cleaning and vehicle cleaning.

NSW Health advises against using rainwater for drinking when an alternative mains water source is available. Guidelines are available in the NSW Health document *Rainwater Tanks Where Public Supply is Available*.

In most aquatic centres, water for drinking and cooking is only a small percentage of total water used, so it is generally not cost effective to treat rainwater to drinking quality.

Rainwater can be harvested for use in pool make-up and filter backwashing, provided it is treated to a sufficient standard before human contact.

Rainwater must be used regularly to ensure tanks are emptied frequently and have enough room to capture more rainwater when needed. This also increases the effectiveness of tanks in reducing stormwater flows from your site. If you use rainwater regularly, it will maintain water quality in the tank, and treatment systems can be kept simple and inexpensive.

### How much rainwater can you catch?

To make the most of your rainwater tanks, it's important to get the right size tank for your needs. To calculate the appropriate size tank, you will need to know:

- the size of the roof area from which water can be collected
- rainfall and climate data for your area
- where water will be used
- how much water you need.

The Australian Bureau of Meteorology can give you average yearly rainfall data and mean number of rainfall days for your region. You can visit their website at [www.bom.gov.au](http://www.bom.gov.au)

Alternatively, Sydney Water has a rainwater tank calculator available at [sydneywater.com.au](http://sydneywater.com.au). This will help you calculate the most cost-effective tank size based on your roof area and demand.

Once you have selected your tank size, consider:

- where the tank will be located – preferably near existing downpipes
- power supply
- pumps
- plumbing
- backflow prevention
- costs
- maintenance requirements
- regulatory and plumbing requirements.



## Rainwater quality

The quality of rainwater collected depends on the location in which it falls, the surface onto which it falls and the standard of storage tanks. The roofs of aquatic centres may collect contaminants like dust, leaves, vegetation, bird faeces and occasionally dead animals. Keeping roofs clean with regular maintenance will improve the quality of collected rainwater and reduce the likelihood of gutters and collection systems becoming blocked.

A first flush device also improves rainwater quality, as the first flush contains most pollutants. This device sits between the roof downpipe and the rainwater storage tank and disposes of the first rainfall runoff collected by your roof. As the first flush contains most pollutants, a properly sized first flush diverter is very effective at improving the quality of collected rainwater.

To maintain water quality, it's a good idea to exclude roof areas that:

- have frequent public or vehicle access
- have unpainted lead flashing, copper roofing materials or bitumen paint
- are exposed to contaminants, such as bleed from hot water heaters and air conditioners, and emissions from flues and chimneys or nearby industrial processes.

The inlet and overflow of the tank should have mesh covers and strainers to stop mosquitoes and other insects from getting into the tank and breeding. This improves water quality and stops your tanks from causing a public health nuisance.

Rainwater collected from paved areas, including forecourts, footpaths, car parks and roads, generally contains far more pollutants. This is typically referred to as stormwater.

## Rainwater treatment

The greater the degree of human contact and the higher the chance of ingestion of the rainwater, the more effort required to manage water quality and treatment systems.

Little or no treatment of water is needed if roofs and tanks are well maintained, the water is free of contaminants, and it is to be used for outdoor uses and toilet flushing. Some centres may choose to treat rainwater further, especially if it is to be used indoors, to minimise risk to patrons.

Treatment systems are likely to be needed if rainwater is required for more sensitive uses and many people are likely to come into contact with it, or if there is a high chance of ingestion.

## Regulatory requirements

If rainwater is going to be used for toilet flushing, in pool make-up or filter backwashing, it will probably need top-ups from mains water. In this case, you need to install a backflow prevention device at the property meter to ensure the rainwater cannot contaminate the mains water. More information on backflow prevention can be found in Part 4 of this guide.

Plumbers should complete this work following the *NSW Code of Practice Plumbing and Drainage* and meet the specific technical requirements for rainwater tank plumbing detailed in *Guidelines for the installation of rainwater tanks on residential properties: part 1 plumbing requirements*.

You should also contact your local council to discuss regulations that apply to installing rainwater tanks, stormwater re-use systems, and greywater or blackwater re-use systems. In New South Wales, property owners can install tanks of up to 10,000 L without development approval, providing set conditions are met for:

- siting and plumbing
- installing first flush diverters
- mitigating noise from pumps
- controlling mosquitoes.

To find out about these conditions, contact your local council and review the conditions in *State Environmental Planning Policy No. 4* at [www.planning.nsw.gov.au/planningsystem/sepp1.asp](http://www.planning.nsw.gov.au/planningsystem/sepp1.asp)

Larger tanks or tanks that do not meet these conditions usually need local council development approval.

### Costs and benefits of rainwater tanks

Rainwater harvesting is a popular way to save drinking water, although it is usually less cost effective than other measures for reducing water use, such as leak reduction and improved efficiency.

If rainwater is used for purposes such as toilet flushing, pool make-up or filter backwashing, it can reduce mains water use. Rainwater harvesting can also reduce stormwater discharges from large sites, which can ease some of the negative environmental effects of urban stormwater.

Installing a large rainwater harvesting system in a new aquatic centre may reduce or remove the need to build an on-site detention system for stormwater.

### Equipment and cleaning

You can improve the quality of stored rainwater, minimise the need for complex treatment systems and keep costs down by:

- cleaning your gutters regularly
- installing an adequately sized first flush device
- removing sludge from tanks every two to three years as required.

Tanks, gutter systems, pipe work and warning signs should meet Australian standards.

To use tank water, you need to install pumps to ensure enough operating pressure. You should include these costs in the overall cost of rainwater tank installation.

Your plumbing contractor or hydraulic engineer can advise you.

### Useful references

NSW Health *NSW Health Private Water Supply Guidelines 2007*, [www.health.nsw.gov.au/public-health/ehb/water/private\\_supplies.html](http://www.health.nsw.gov.au/public-health/ehb/water/private_supplies.html)

EnHealth, *Guidance on the use of rainwater tanks 2004*, [www.enhealth.nphp.gov.au/council/pubs/pdf/rainwater\\_tanks.pdf](http://www.enhealth.nphp.gov.au/council/pubs/pdf/rainwater_tanks.pdf)

Environmental Protection and Heritage Council (EPHC), *Australian Guidelines 21 For Water Recycling: Managing Health And Environmental Risks (Phase 2) Stormwater harvesting and reuse, 2009*, [www.ephc.gov.au/sites/default/files/WQ\\_AGWR\\_GL\\_Stormwater\\_Harvesting\\_and\\_Reuse\\_Final\\_200907.pdf](http://www.ephc.gov.au/sites/default/files/WQ_AGWR_GL_Stormwater_Harvesting_and_Reuse_Final_200907.pdf)

NSW Health, *Use of Rainwater Tanks Where a Public Water Supply is Available*, [www.health.nsw.gov.au/policies/gl/2007/GL2007\\_009.html](http://www.health.nsw.gov.au/policies/gl/2007/GL2007_009.html)

## Chapter 24

# Wastewater

Wastewater can be a valuable and reliable alternative source of water. It needs careful management and treatment before it can be re-used as it contains a range of contaminants.

Wastewater is generally described by three different terms:

**Greywater** includes wastewater from hand basins, showers and laundries. Greywater may be contaminated by human waste. Filter backwash wastewater may also be regarded as greywater. Its treatment and re-use is more complex, because it may be alkaline and can contain large amounts of sediments, fats and water treatment chemicals. More information about using filter backwash water and a risk assessment matrix are provided in Appendix 1.

**Blackwater** (domestic wastewater) is wastewater from toilets and bidets that is heavily and directly contaminated with human waste and solid materials, such as toilet paper. Blackwater is likely to have high levels of bacterial contamination and can be highly infectious. Recycled blackwater must not be used in pool make-up.

**Wastewater** is a combination of blackwater and greywater, as well as trade wastewater from commercial and industrial activities. Treated wastewater must not be used in pool make-up.

### Re-using greywater

Greywater with high levels of pathogen contamination and oils and grease can be used for below ground irrigation with little treatment. However, with a high level of treatment greywater can be used for above ground irrigation and indoor uses, such as toilet and urinal flushing.

Before using greywater:

- identify the contaminants in your greywater
- calculate how much greywater you generate now and how much you can potentially generate
- decide on intended uses for greywater, such as irrigation or toilet flushing
- determine how much contact people will have with re-used greywater
- identify any environmental risks associated with greywater re-use

- decide on the treatment processes you will use, and ensure they will remove contaminants and make water safe for users and the environment.

Preventing hazardous contaminants from going into a greywater system is the best way to ensure greywater quality. This can be done by:

- excluding kitchen waste, because of high levels of oil, grease and bacterial contamination from food waste (unless your system is specifically designed to handle this)
- excluding laundry water when items soiled with faeces or vomit are washed, as they have high levels of bacterial contamination
- ensuring household and garden chemicals are not disposed of into greywater, because chemicals can harm soils and the environment.

It is important to communicate with aquatic centre staff and cleaners to help them understand what they can put down the drain and when water must be diverted to the wastewater system.

If you plan to use greywater for irrigation, ensure the receiving soils can hold the volume of water. To find out the water holding ability of your soils, you may need a suitably qualified consultant to carry out a soil assessment.

There are two types of devices commonly available to re-use greywater:

1. Greywater diversion devices.
2. Greywater treatment devices.

### Greywater diversion devices

If you are confident that your greywater system does not collect kitchen wastewater or contain heavy pathogen loads, you can use a greywater diversion device to divert greywater to below ground irrigation.

Below ground greywater irrigation systems must be installed at least 10 cm underground to reduce human exposure to potential pathogens.

Diversion devices are not allowed to store greywater because harmful pathogens can grow in storage tanks and unpleasant odours can develop. Any greywater that is not used for irrigation must be disposed of to the wastewater system. To avoid waterlogging your soil, don't apply greywater after rain. Diversion devices must have a screen to remove any large pollutants, such as lint or twigs, which could clog spray systems or pumps.

Greywater must be diverted to the wastewater system if there is a known source of faecal contamination or an outbreak of infectious disease among users of the aquatic centre where greywater is sourced.

Diversion devices can be operated by gravity or pump. Pump devices have a surge tank that controls the amount of greywater sent to irrigation. The surge tank should not be used as a storage tank.

### Greywater treatment systems

A treatment system must be used if greywater contains kitchen wastewater, or if you want to use greywater for toilet flushing, washing machines or unrestricted garden irrigation.

A complete greywater treatment system may include:

- greywater septic tanks
- aerated wastewater treatment systems
- intermittent sand filters
- soil filters
- wetlands.

These processes remove pollutants including solids, but only the aerated wastewater treatment system removes harmful bacteria.

Disinfection is needed where there is human contact with re-used greywater. When secondary treated greywater is disinfected using active disinfectants, such as chlorine, bromine, ozone or ultraviolet light, the levels of

harmful bacteria are reduced, making greywater safe for uses where there is more human contact.

### Using blackwater and wastewater

The amount of greywater generated on-site can sometimes be insufficient to fulfil demand for re-use water. It may be more efficient to use blackwater or wastewater. While these wastewater streams are more heavily contaminated and need more treatment, having access to a larger amount of wastewater may be more cost effective.

Recycled blackwater must not be used in pool make-up. Centre owners can either use the wastewater generated on-site, or access nearby wastewater mains. Accessing wastewater from nearby mains is known as sewer mining. If businesses are accessing wastewater from Sydney Water's mains, they need approval from Sydney Water and their local council.

Centres that want to sewer mine should discuss their plans with Sydney Water to make sure the project is possible and the existing wastewater infrastructure can cope with the proposed project. If the project is possible, Sydney Water will provide initial development and construction approvals.

### Costs and benefits

Wastewater can provide a regular source of alternative water. Well-run systems can greatly reduce demand on mains drinking water supply.

Given the costs of setting up a well-run wastewater re-use system, it's important you have an accurate idea of how much wastewater you will be collecting, and how much you will be using. If you make your aquatic centre as water efficient as possible, you can keep the size of any water re-use scheme small and reduce your capital and operating costs.

### Regulatory requirements

In NSW, local government approval is needed to install and operate wastewater maintenance systems. This also applies to greywater re-use systems. Your local council may give approval under the *Local Government Act 1993 and Regulations*. The NSW Office of Water and NSW Health may advise local councils about applications.

Local government approval is not needed if an environmental protection licence is already in place under the *Protection of the Environment Operations Act 1997*.

Recycled water schemes should meet the *Australian Water Recycling Guidelines: Managing Health and Environmental Risks (2006)* and the *Interim NSW Guidelines for the Management of Private Recycled Water Schemes*. Refer to [www.waterforlife.nsw.gov.au/recycling/](http://www.waterforlife.nsw.gov.au/recycling/) guidelines for a full list of appropriate water recycling guidelines.

### Risk management and treatment

To manage the risks of filter backwash water, greywater or recycled water systems and to gain approval to install and operate one, follow the steps in the table below.

**Table 15 – Risk management protocol for use of recycled water**

Action	Detail
<b>Conduct a risk assessment</b>	Risk assessment will identify likely health and environmental risks in the sources of wastewater and its intended uses. This will guide the design of a treatment system that will produce appropriate quality water that is safe for users and the environment. A risk assessment matrix for different types of pools can be found in Appendix 1.
<b>Include multiple barriers</b>	Multiple barrier treatment systems can produce optimum quality water and provide multiple points at which pollutants can be removed. The types of barriers used will depend on the contaminants in the source water and the sensitivity of its intended uses. Examples of barriers include: <ul style="list-style-type: none"> <li>• restricting your wastewater sources to avoid hazardous pollutants</li> <li>• filtering wastewater with a membrane</li> <li>• chemical treatment</li> <li>• restricting access to recycled water</li> <li>• installing signs.</li> </ul>

Action	Detail
<b>Disinfect to remove harmful bacteria</b>	Wastewater should be disinfected to ensure all harmful bacteria are removed. Substances such as chlorine and bromine provide residual disinfection that prevents regrowth of harmful bacteria for some time. UV and ozone disinfect, but do not provide residual disinfection.
<b>Identify the critical control points</b>	<p>Critical control points are steps or procedures in your recycled water system, which are essential to eliminate a water quality hazard or reduce it to acceptable levels.</p> <p>Numerical limits should be set for each critical control point so that managers of the water system can monitor it, ensure that it is operating correctly and take corrective action if necessary.</p>
<b>Develop a system management manual</b>	<p>A system management manual should be developed so that everyone involved with the system knows how it works, who is responsible for managing it, how to respond to alarms or malfunctions and how to report on system performance.</p> <p>A draft system manual should be submitted to your local council with your initial application. It should be updated when the results of system testing and validation are known.</p>
<b>Test the system</b>	If your local council gives approval to install the system, the performance of the system must be tested over 12 weeks to make sure it is working correctly and producing water of an acceptable quality. During this time, treated water should be disposed of to the wastewater system. After approval to operate is given, an additional four weeks' testing is needed to make sure it is operating as expected.
<b>Set alarms</b>	Critical control points in the system should be monitored continuously. Alarms on critical control points should be established, so that system operators are alerted if water quality targets are not met, or if parts of the system stop operating. Water from the system should be immediately diverted to the wastewater system.
<b>Responsibility</b>	Clear responsibility should be given to a person or organisation to manage the system.
<b>Signage</b>	Install signs and colour code plumbing pipes and fixtures. This will help prevent human contact with recycled water and operate as an additional barrier. Conduct regular plumbing compliance checks to detect cross connections.
<b>Comply with plumbing requirements</b>	If your wastewater re-use system is in Sydney, notify Sydney Water of any changes to your plumbing. Sydney Water will review your system to make sure there are no potential health threats or impacts on the drinking water system. Talk to your Sydney Water Business Customer Service representative to make sure there are no changes to your customer agreement.

## Useful references

Water for Life – recycling guidelines  
[www.waterforlife.nsw.gov.au](http://www.waterforlife.nsw.gov.au)

NSW Government  
Department of Water and Energy, *Interim NSW guidelines for management of private recycled water schemes, May 2008*,  
[www.waterforlife.nsw.gov.au](http://www.waterforlife.nsw.gov.au)

Environmental Protection and Heritage Council (EPHC), *National Water Quality Management Strategy – Australian Guidelines for Water Recycling: Managing Health and Environmental Risks (Phase 1) – November 2006*,  
[www.ephc.gov.au/sites/default/files/WQ\\_AGWR\\_GL\\_Managing\\_Health\\_Environmental\\_Risks\\_Phase1\\_Final\\_200611.pdf](http://www.ephc.gov.au/sites/default/files/WQ_AGWR_GL_Managing_Health_Environmental_Risks_Phase1_Final_200611.pdf)

NSW Health, *Advisory Note 4 – Sewage Management Facility Accreditation Criteria Based on the Final Application of Treated Effluent and Risk of Disease Transmission, 2006*,  
[www.health.nsw.gov.au/resources/publichealth/environment/water/adnote4\\_pdf.asp](http://www.health.nsw.gov.au/resources/publichealth/environment/water/adnote4_pdf.asp)

*Environmental Protection and Heritage Council (EPHC), Australian Guidelines 21 For Water Recycling: Managing Health And Environmental Risks (Phase 2) Augmentation of Drinking Water Supplies, 2008*,  
[www.ephc.gov.au/sites/default/files/WQ\\_AGWR\\_GL\\_ADWS\\_Corrected\\_Final\\_%20200809.pdf](http://www.ephc.gov.au/sites/default/files/WQ_AGWR_GL_ADWS_Corrected_Final_%20200809.pdf)

## Chapter 25

# Groundwater

Groundwater, sometimes known as bore water, may be an alternative source of water for some aquatic centres. It is found in the cavity spaces or in the fractures of rock formations beneath the earth's surface. This can be of good quality, suitable for drinking, domestic use, stock and irrigation.

### Using groundwater

One of the most common uses of groundwater is irrigation. Some aquatic centres in Sydney have licences for groundwater extraction.

The quality of groundwater can be variable, and the costs to access it depend on the depth at which it is found and local geography.

The NSW Office of Water keeps a groundwater database of registered bores in NSW. The Office of Water can give you general information about the likely quality of water, based on nearby bores.

It is important to consider the effect of groundwater on soil quality as it may contain high levels of dissolved salts. Some soils may be more sensitive than others, so it's a good idea to organise a soil analysis.

Groundwater can be used to flush toilets and urinals. Groundwater is used for toilet and urinal flushing, at Des Renford Aquatic Centre at Randwick.

Before using groundwater consider:

- how much groundwater you need
- if groundwater can deliver a sustainable amount of water
- what treatment it may need
- other land uses in the groundwater catchment and the potential for contamination
- what approvals you need before drilling a bore and using groundwater.

### Groundwater quality

The quality and properties of groundwater affect the range of end uses available. It is important to note that quality varies from one site to another.

The common dissolved solids found in groundwater include dissolved iron, manganese and hydrogen sulphate. You should also investigate the groundwater's pH and if it is likely to cause corrosion or scaling if not treated before use.

The type of treatment depends on the particular properties of the groundwater you extract and the sensitivity of its uses.

### Regulatory requirements

The NSW Office of Water regulates access to groundwater in New South Wales. Before you sink a bore, you must first obtain approval and a licence from the Office of Water. A licensed driller must construct all bores.

There are embargoes in place for commercial use of groundwater in some areas around Sydney. These include the Botany Sands aquifer in the Eastern Suburbs and around Botany Bay, and the Hawkesbury sandstone aquifer in the Blue Mountains and parts of the Southern Highlands. These embargoes do not allow the Office of Water to accept new water licences. Contact the Office of Water for details about embargoes.



UF Membrane

MITSUBISHI  
FILTER

  
MACHINE  
STARTS  
AUTOMATICALLY





# Part 5

## Managing your wastewater

Part 5 of ***Best practice guidelines for water management in aquatic leisure centres*** is aimed at council and aquatic centre sustainability officers and facility managers. It can help you manage your wastewater better and comply with trade waste and backflow prevention requirements.

## Chapter 26

# Sewerage Usage Discharge Factor

Wastewater usage charges apply to non-residential properties (Sewerage Usage Discharge Factor). The charge applies to each kilolitre of wastewater discharged to the wastewater system. It is found in your water bill as a percentage of the combined volume of drinking and recycled water used and discharged into the wastewater system.

The SUDF includes all discharge to the wastewater system, that is liquid trade waste and domestic wastewater and, in some cases, first flush stormwater from open areas.

SUDF usually varies from 70% to 95%. For aquatic centres using alternative water sources SUDF may be calculated differently. Business customers can request a review of their SUDF. This involves monitoring the flow to the wastewater system over one year. Contact your Business Customer Services representative for assistance.

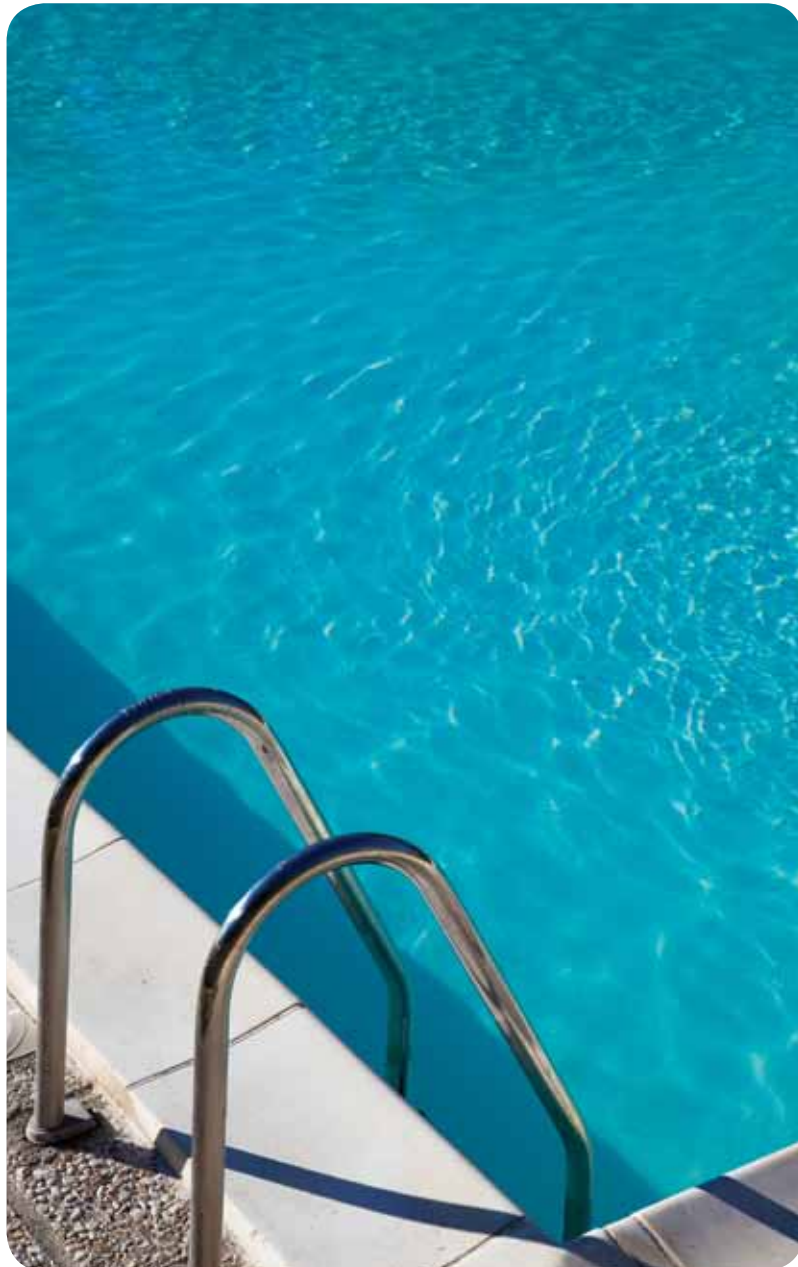

## Chapter 27

## Volume measurement

It is important to accurately measure the volume of backwash wastewater discharged to the wastewater system. This will help you understand if your sewerage usage discharge factor is correct.

Ask your Sydney Water Business Customer Service representative how you can measure your wastewater discharge more effectively. There are also consultants who can assist you for a fee.

A magnetic flow meter, located on the discharge line, is a recommended volume measuring device. Magnetic flow meters calculate volumetric flow and have no moving parts. As the

wastewater passes through the magnetic field it produces a voltage, which is used to calculate volumetric flow. Refer to Figure 20 for an illustration of a magnetic flow meter. These meters are ideal for:

- wastewater and dirty water monitoring
- applications with low pressure drop.

However, there are specifications that need to be followed. These are detailed

in Sydney Water's *Flow measure for trade waste* fact sheet, available at [sydneywater.com.au](http://sydneywater.com.au)

Magnetic flow meters require yearly service and calibration and generally do not work with:

- hydrocarbons
- distilled water
- many non-aqueous solutions.

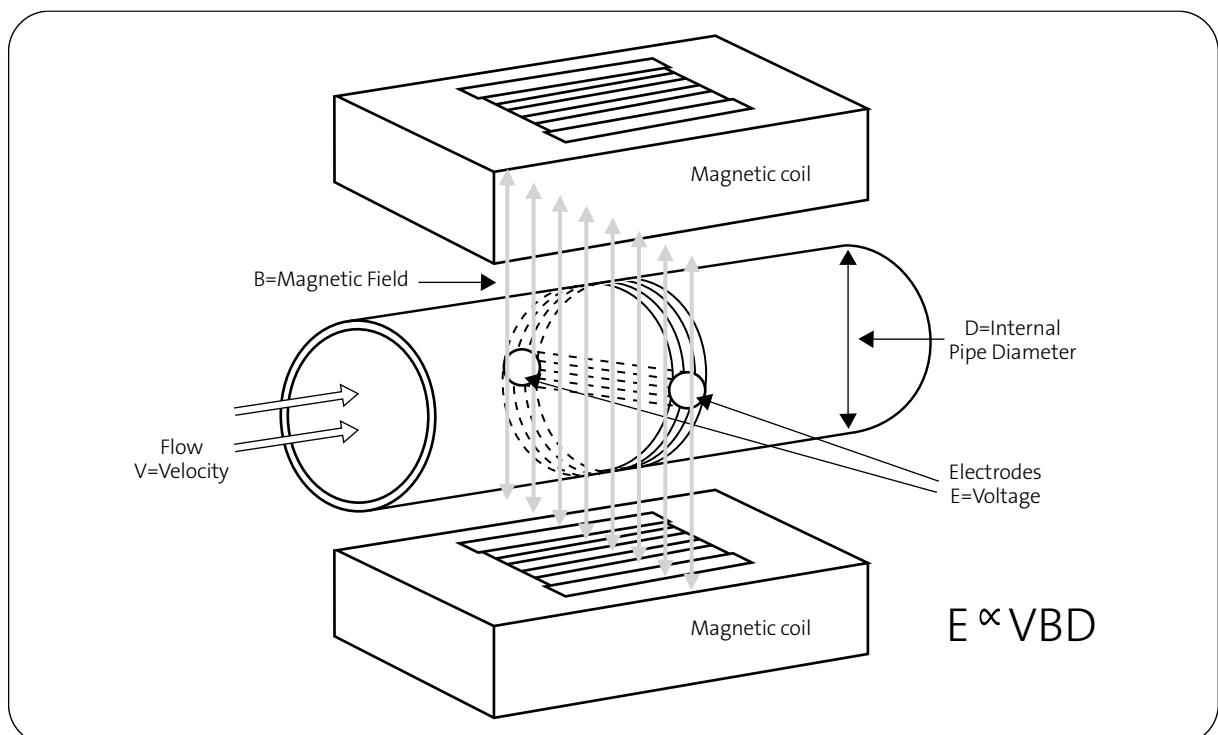

Figure 20 – Magnetic flow meter

## Chapter 28

# Trade wastewater

Trade wastewater is any liquid and substances in it, produced by an industrial or commercial activity at a business and disposed of through the wastewater system. In some cases, trade wastewater contains high concentrations of substances that could harm people or the environment, corrode or block sewer pipes, create odours, or cause hydraulic and treatment problems at Sydney Water's wastewater treatment plants.

Trade wastewater is different to domestic wastewater, which comes from toilets, sinks, showers, basins and washing machines within households.

Sydney Water has a *Trade Waste Policy*, the objectives of which are to:

- protect the health and safety of all people working in and around the wastewater system by applying strict standards for harmful substances
- protect receiving environments from harmful substances that may be in wastewater treatment plant effluent as a result of trade wastewater
- protect the wastewater system and wastewater treatment plants from damage due to harmful substances from trade waste sources
- assist Sydney Water to meet relevant environmental and other regulations
- assist treatment plants to process wastewater and produce recycled water and biosolids of guaranteed quality
- encourage waste minimisation, cleaner production and water efficient practices in the commercial and industrial sectors.

For more information, please refer to Sydney Water's *Trade Waste Policy* at [sydneywater.com.au](http://sydneywater.com.au).

Customers who need to discharge trade wastewater into the wastewater system must first obtain written permission from Sydney Water. Depending on the type of customer, a consent or permit will be provided by Sydney Water. These describe the conditions in which Sydney Water will accept trade wastewater.

### Types of trade waste customers

There are three types of trade waste customers: deemed, commercial and industrial.

#### 1. Deemed customers are:

- those considered by Sydney Water to have 'deemed processes'
- allowed to discharge small quantities of wastewater to the wastewater system without negotiating a Commercial Trade Wastewater Permit, but they must meet specific standards of pre-treatment and other requirements
- excluded from trade wastewater charges.

#### 2. Commercial customers are:

- those with standard commercial processes as defined by Sydney Water
- retail food outlets, motor vehicle and small photographic, printing and X-ray processes
- required to apply for a Commercial Trade Wastewater Permit. These processes have prescribed pre-treatment requirements and standard charges.

#### 3. Industrial customers are:

- those which include food manufacturing, metals and surface coating, waste processing, waste treatment and disposal, oil refineries and oil recycling
- required to sign an Industrial Trade Waste Consent with Sydney Water to discharge wastewater.

## Chapter 29

# Trade waste in aquatic centres

### Kiosks and kitchens

If the aquatic centre has a kiosk that prepares hot food and/or a commercial kitchen discharging into the wastewater system, it requires a Commercial Trade Wastewater Permit.

Pre-treatment may be required to ensure that oil, grease and food solids are removed from the wastewater before it is discharged into the wastewater system. Sydney Water does not allow sink-to-sewer disposal units (also called in-sink food waste disposal units or garbage grinders) in non-domestic buildings.

For more about grease arrestors, in-sink and in-floor bucket traps, Smart Rinse spray valves, foot or knee sensor controlled taps or to request marketing material, email [businesscustomers@sydneywater.com.au](mailto:businesscustomers@sydneywater.com.au) or call 13 20 92.

### Swimming pools

Swimming pools have filters to remove contaminants from the pool water. To keep the filters working efficiently, they must be backwashed regularly to flush out contaminants and dirt. Contaminants can include organic matter such as hair and skin, small particles such as sediments, dirt and leaves, oily residues from sunscreens



In-floor bucket traps capture food scraps, cutlery and cleaning cloths that may have fallen on the floor. They prevent these items from entering the grease arrestor and encourage thorough cleaning practices

and lotions, and harmful bacteria. However, treated pool water also contains levels of chlorine and chlorine disinfection by-products and Total Dissolved Solids (TDS).

Aquatic centres require a Trade Wastewater Permit from Sydney Water to discharge pool backwash water to the wastewater system. This covers:

- wastewater treatment
- volume of treatment and discharge
- flow rate of discharge to sewer
- magnetic flow meter type and location, for verification of discharge.

Sydney Water is prepared to accept swimming pool backwash to the wastewater system providing a number of principles for managing wastewater are maintained.

These principles consider the available capacity of the wastewater system and ensure that large particles, particularly sand and grit, are captured and removed before discharge.

### Backwash water holding tank and controls

A backwash water holding tank is used, before wastewater is discharged into the wastewater system. Figure 21 shows a typical backwash water holding tank. This tank has three major benefits:

1. It allows sand and grit in the backwash water to settle out.
2. It improves the quality of the wastewater.
3. It controls the rate of discharge to the wastewater system.

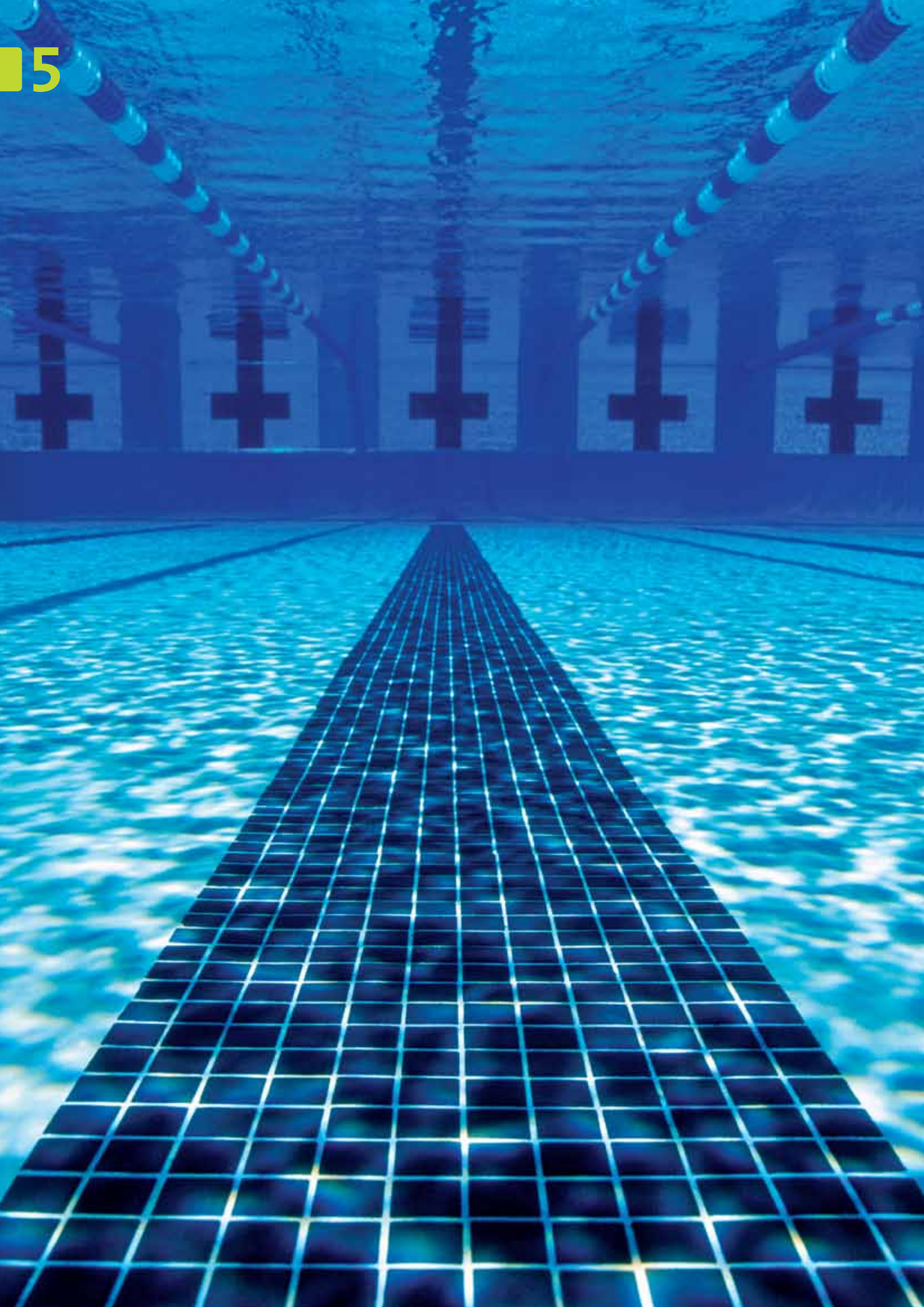

The typical acceptable flow rate to the wastewater system is two litres a second. If a higher discharge rate is needed, consult your Business Customer Services representative. Sydney Water will assess your request and determine if there is sufficient capacity in the wastewater system.

### Size of backwash water holding tank

The tank must be sized to capture the largest backwash cycle of the pool plus 15%. This includes 10% to account for any overflows in case of

excess backwash pumping and five per cent for sludge containment capacity.

### Shape of backwash water holding tank

The shape of the backwash water holding tank must encourage the settling of suspended solids to form sludge. It may have either a sloping floor or a conically shaped base to enhance settling of solids and their removal.

A high level cut-off switch must be fitted to stop the backwashing cycle and prevent any overflow to

the wastewater system or stormwater. A low level cut-off switch is required to maintain the sludge containment capacity.

### Maintenance of backwash water holding tank

At a minimum, the tank should be de-sludged regularly, preferably every six months. However, check the tank monthly as the frequency of de-sludging is different for each system. This depends on the size of the tank, frequency of backwashing and water quality.

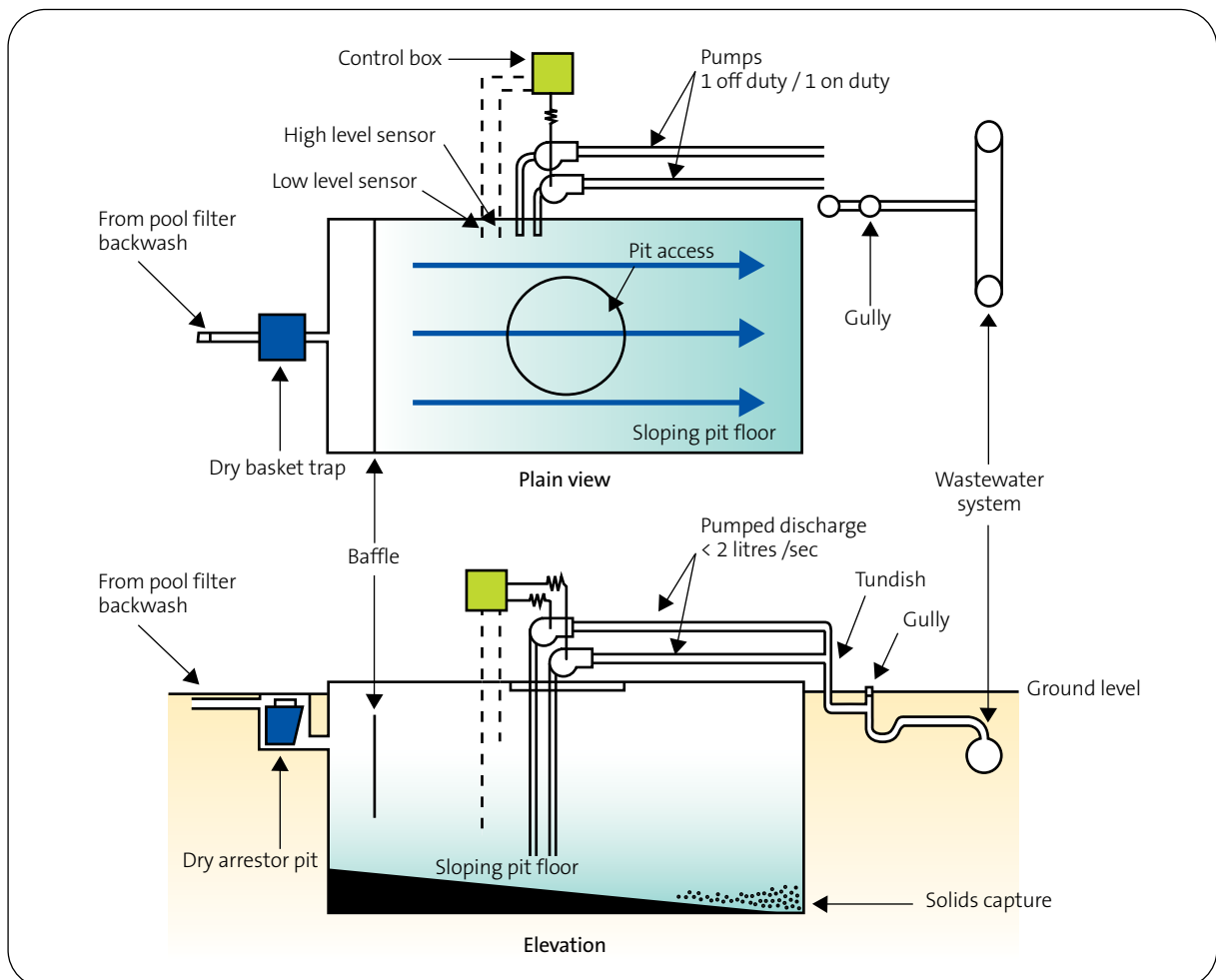

Figure 21 – Key features of a typical backwash water holding tank  
Image left – Swimming pools have filters that remove contaminants such as hair and skin, sunscreen, dirt, leaves and bacteria, leaving clean water

## Chapter 30

## Backflow prevention

Backflow is water flowing in reverse to its normal direction. It occurs when water pressure in the water main is reduced or the customer is using water at a higher pressure than the pressure supplied by Sydney Water. This can cause water to flow back into the drinking water supply system from a potentially polluted source. Backflow can occur

through a series of events as outlined in Figure 22 below.

To protect Sydney Water's water supplies, all water services must meet the requirements of the *NSW Code of Practice for plumbing and drainage and Australian/New Zealand Standard for plumbing and drainage Part 1: Water services (AS/NZS 3500.1)*.

Because aquatic centres use chemicals to treat swimming pool water, these chemicals have the potential to contaminate the drinking water supply if backflow occurs. To protect Sydney Water's drinking water supply, you must install a backflow prevention containment device.

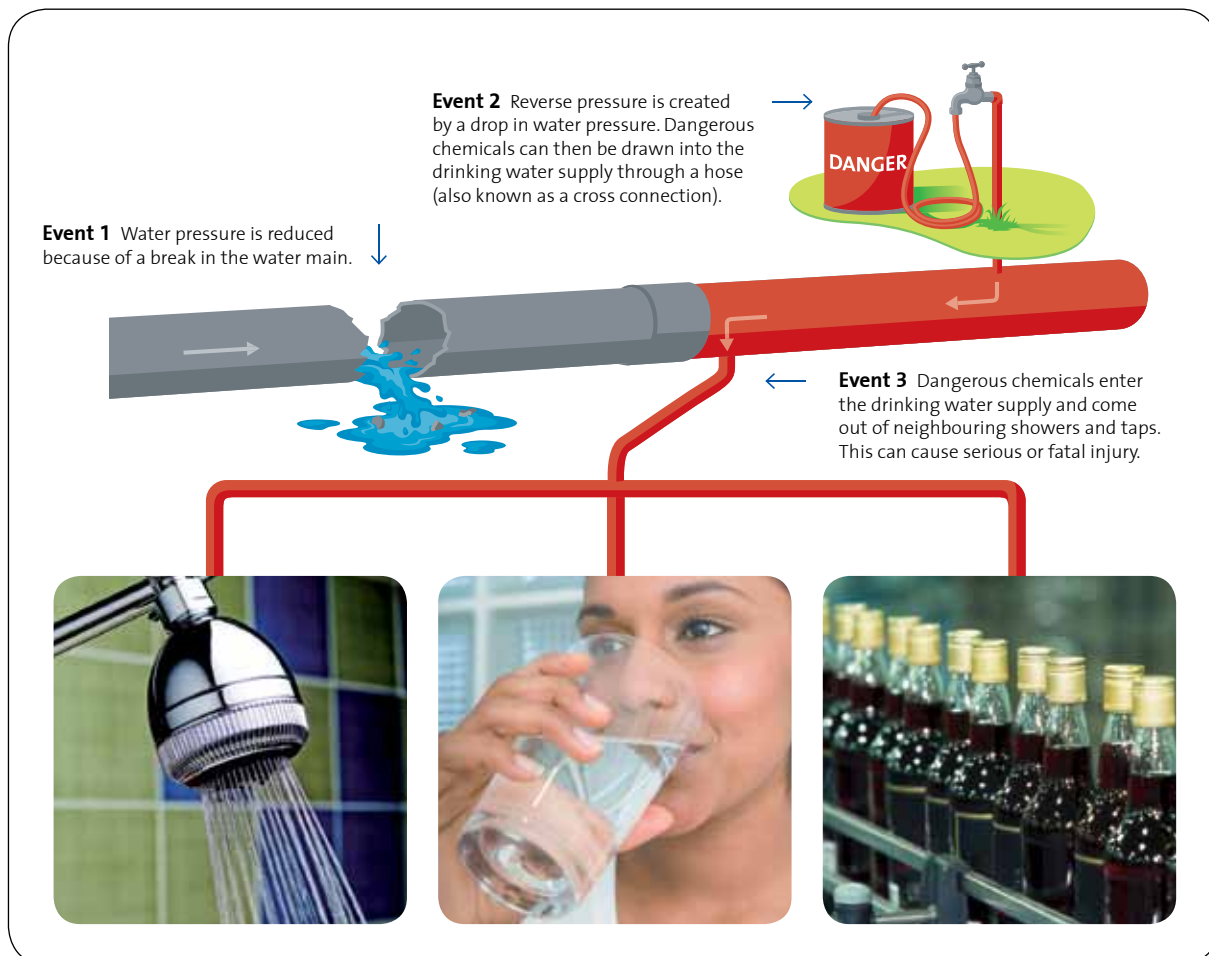

Figure 22 – Backflow from aquatic centres could potentially contaminate the drinking water supply

## Backflow prevention containment device

A backflow prevention containment device ensures that the drinking water supplied by Sydney Water cannot be contaminated by any actual or potential cross connections from a customer's property.

You must have a backflow prevention containment device on all water supplies entering the property, regardless of the supply type or metering arrangements. All backflow prevention containment devices must be installed at your property boundary, on the outlet side of all master water meter(s) supplying the property. In cases where there is no master meter, the containment device must be on the water supply where it enters the property boundary.

The hazard rating of the processes carried out on your property determines what type of device you must install. Consult a licensed plumber with backflow prevention accreditation to determine your property's needs.

The three hazard ratings identified by AS/NZS 3500.1 are:

- High hazard – any condition, device or practice which, in connection with the water supply system, can cause death.
- Medium hazard – any condition, device or practice which, in connection with the water supply system, can endanger health.
- Low hazard – any condition, device or practice which, in connection with the water supply system, is a nuisance but does not endanger health or cause injury.

The property owner must also provide zone and individual backflow protection from hazards within their property, as specified in AS/NZS 3500.1.

For more information on backflow prevention, visit [sydneywater.com.au](http://sydneywater.com.au)





# Appendix 1

## Risk management for using alternative water sources

Appendix 1 of *Best practice guidelines for water management in aquatic leisure centres* is aimed at aquatic centre managers and pool operators. It gives information and risk assessment matrixes for using alternative water sources for pool make-up in aquatic centres.

## Introduction

More expectations are being placed on aquatic facilities and the community to conserve water and live more sustainably.

When alternative water sources are used for pool make-up, pool operators must have a risk management process in place to ensure the health and safety of patrons and the public. Water quality and the associated risks of using alternative water sources must be reviewed each year.

This appendix outlines the health risk of using alternative water sources at aquatic centres in New South Wales. It provides a risk assessment matrix and some controls to reduce these risks to acceptable levels.

The alternative water sources covered in this appendix include:

- bore water
- rainwater
- stormwater
- filter backwash water
- greywater sourced from showers/washing machines
- Class A recycled water available from a local water authority's recycling plant.

### NSW Government regulation

Public health requirements for pools are set out in the *NSW Public Health (Swimming Pools and Spa Pools) Regulation 2000*.

The regulation has provisions for:

- disinfecting water in pools
- maintaining pool surrounds
- inspecting pools
- closing pools when there is a risk to public health.

The *NSW Health Public Swimming Pool and Spa Pool Guidelines* assist swimming pool operators to meet the requirements of the *NSW Public Health (Swimming Pools and Spa Pools) Regulation 2000*. NSW Health is currently reviewing the guidelines to create two new documents:

1. *NSW Health Draft Guidelines for Disinfecting Public Swimming Pools and Spa Pools* specifies the required disinfection and treatment for public swimming pools and spa pools operations.
2. *NSW Health Draft Public Swimming Pool and Spa Pool Code of Practice* explains swimming pool operation including disinfection and treatment, pool chemistry and risk assessment.

### Health risks associated with water use in aquatic centres

The largest risk to public health in swimming pools and aquatic centres are microorganisms.

Whether alternative water sources are being used or not, pool operators must control microbial risks to bathers.

The microorganisms that present a risk to bathers are:

- bacteria (such as *E.coli*, coliforms and pseudomonads)
- protozoans (such as *Cryptosporidium parvum*, and *Giardia lamblia*).

Bacteria can be easily controlled in swimming pools if:

- appropriate water balance and residual disinfection is maintained at all times (the level of free chlorine with regard to the sanitiser, pH and other chemical parameters)
- water is continuously circulated through the pool and filters
- the pool and filters are being regularly cleaned (including periodic disturbance to or cleaning of any zones with poor circulation).

Protozoans are harder to control than bacteria as they are generally chlorine resistant. These types of microorganisms are seen as a major microbiological contamination risk from alternative sources of water used in pool make-up.

## Chapter 31

# Factors affecting microbial risk

Figure 23 shows the factors affecting the microbial content of a pool. These are:

- inherent – the type and design of the pool and its equipment
- operational – the operation of the pool such as water balance and levels of disinfection
- introduced – the cleanliness of bathers and the quality of the pool make-up water.

### Inherent factors

The inherent factors affecting microbial risk to a pool relate to the type of pool, its design and its associated equipment. Although little can be done about these factors except through a retrofit or an upgrade, understanding the risk that inherent factors present leads to better

decisions being made with water savings and re-use in mind.

### Type of pool

The pool size reflects the ability of the pool to dilute any introduced contaminants. The more diluted the contaminants are, the less likely they are to reach bathers before coming into contact with the sanitiser or filter. The following relationship has been identified for inherent microbial risk:

- The smaller the pool depth, the higher the risk associated with the pool.
- The larger the bather loading on a pool (ie the number of bathers per unit volume), the higher the risk. Figure 24 shows the types of pools in an

aquatic centre in order of increasing microbial risk. An Olympic sized pool is usually the deepest pool with the smallest bather load and the greatest capability for dilution. A toddler swimming pool or wading pool is usually the shallowest pool with the highest bather load.

Often, a toddler pool may not have its own disinfection and filtration system, sharing it with a larger, deeper pool. In this case, this risk hierarchy still applies. Bathers are exposed to contaminants while in the pool, and each pool has a different level of contaminants based on bather load and depth.

Learn-to-swim pools, general purpose and leisure pools usually have a similar depth. The difference between the

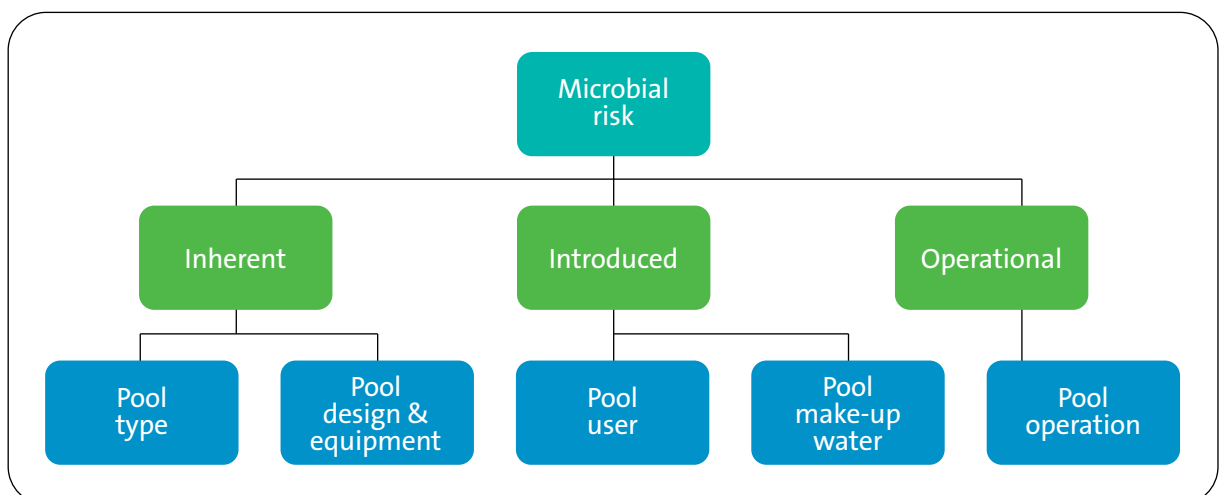

Figure 23 – Factors affecting microbial risk in an aquatic centre

risk of each pool is related to the bather load. Hydrotherapy pools are medium risk pools with a risk rating between general/leisure pools and learn-to-swim pools.

### Pool design and equipment

The pool design also influences the level of microbial risk. Bathers are exposed to contaminants after they have been introduced to the pool by other bathers and before they have been treated by the residual sanitiser or have passed through the filter.

Smaller pools, particularly wading pools, can lose their free chlorine disinfectant levels (residual sanitiser) more rapidly than deeper pools due to their higher concentration of contaminants. Where filter systems are not independent, free chlorine disinfectant levels may be sufficient for the deeper pool but not the shallower pool, due to the difference in concentration of contaminants in each pool. Install a separate filter system for each swimming pool. This will help you control

water balance for the specific conditions of each pool.

Modern pools use more efficient filters with faster turnover rates. Deeper, larger pools are generally equipped with better filtration, disinfection and pump systems, improving their water quality control. Upgrade old filter systems before using alternative water sources. This will give you better control over water quality and microbial risk and may help you reduce water use by improving water efficiency.

Protozoans can pass through filter media, but are usually removed with dirt and other contaminants during filter backwashing. To minimise filter breakthrough, maintain all pool filters regularly and check for signs of filter breakthrough. Filter efficiency can also be improved in some cases by filter aids, such as coagulants and flocculants.

### Introduced factors

Introduced risks are microorganisms that may enter the pool from bathers and when make-up water is added to the pool.

### Pool users

Microorganisms can be present on bathers' bodies, including faecal matter, and introduced to the pool accidentally. They are transferred to other bathers when they are ingested. Bathers that are not toilet trained (babies and toddlers) or bathers that have poor urinary or bowel control (the elderly and disabled) increase the risk of pool contamination by microorganisms in two ways:

1. Urine in a pool uses up free chlorine, reducing the available free chlorine to kill microorganisms.
2. Faecal matter can contain protozoan parasites such as *Cryptosporidium parvum* and *Giardia lamblia*.

To limit accidental contamination, toddlers and patrons who have poor urinary or bowel control should wear specially designed swimming pants, use toilet facilities before entering the pool, and take regular toilet breaks. Develop an isolation and treatment procedure for faecal contamination events and train staff. Also, discourage toddlers from taking

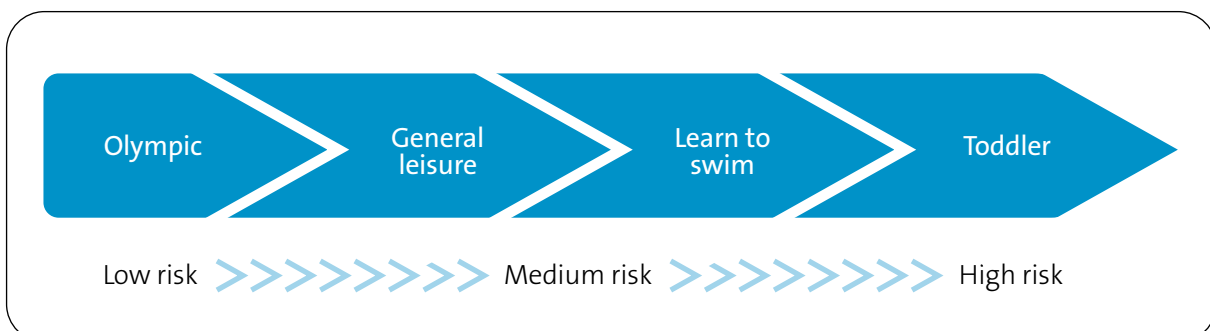

Figure 24 – Microbial risk for various swimming pool types

mouthfuls of pool water. Discourage patrons from using the pool for two weeks after suffering any gastro-intestinal illness.

Often, bathers do not know they are infected. They can introduce faecal matter to the pool accidentally, on their bodies and on dirty hands (not washing hands after changing nappies or going to the toilet). Or they can unintentionally carry it into the pool on their feet. Advise patrons to shower before using the pool, to change nappies in the change room instead of beside the pool, and to wash their hands after changing nappies or going to the toilet.

Once the microorganism has been introduced into the pool, there is a risk it may be ingested by other bathers. Pools with a higher bather load have a greater risk of introducing microorganisms to other bathers. This is because it does not take long

for the microorganism to reach another bather, and the length of time it is exposed to the disinfectant may not be enough to kill it. In pools with a low bather load, the contact time with the disinfectant is higher, so the risk is lower. Figure 25 shows the types of swimming patrons in an aquatic centre, in order of increasing microbial risk.

### Pool make-up water

The water quality and microbial risk of alternative water sources need to be considered before it is used in pool make-up. For example, individual *Cryptosporidium* particles (known as oocysts) can be trapped by matter caught in the pool filter. Because of this, backwash water can contain the *Cryptosporidium* parasite. This water needs to be treated to drinking water quality before it can be used in the pool, but needs only limited treatment if used for toilet flushing.

Water treatment systems need to be designed to address the quality of the source water specifically for its intended end use. The treatment system and resulting water quality need to be validated. Sufficient controls (such as using a multi-barrier approach and an online monitoring system) ensure that each batch of treated water achieves the desired water quality before introduction into a pool.

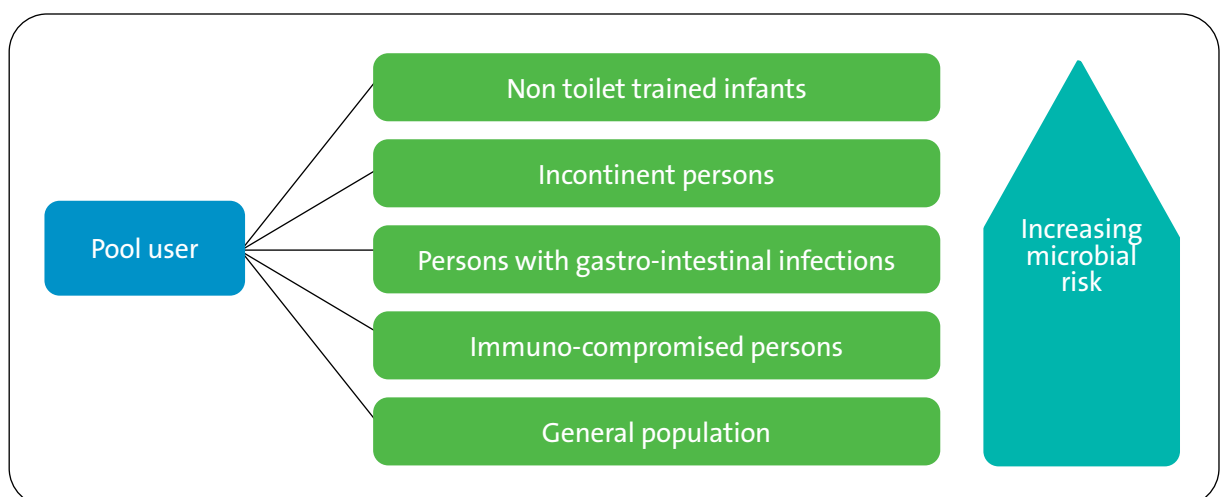

Figure 25 – Microbial risk for various swimming patron types

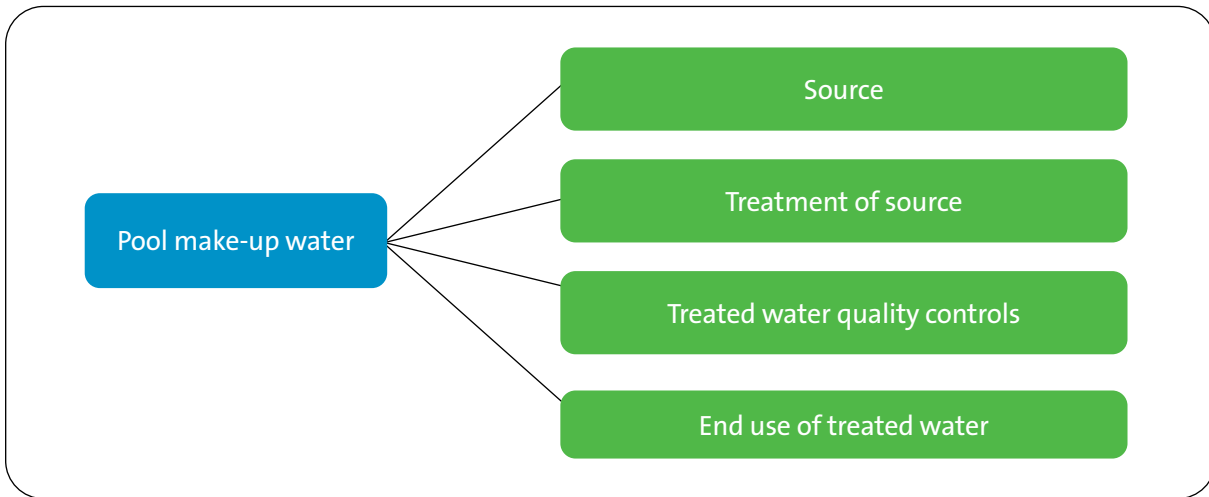

Figure 26 – Considerations for assessing microbial risk for various pool make-up water sources

Figure 26 shows what to consider when you are thinking of using alternative water sources for pool make-up.

Disinfect alternative water sources before delivery into the pool. The disinfection effectiveness also needs to be considered when designing a re-use system.

Alternative disinfection treatments include ozone, and ultraviolet (UV) light. Use a UV or ozone to system to supplement chemical disinfection and to reduce chloramines.

### Operational factors

Pool operators need to maintain water balance to make sure disinfection is effective. Water balance parameters and filter system effectiveness should be checked each day. Maintaining correct water balance and disinfection control in the pool water is more effective than microbiological testing for ensuring water quality. This is because:

- tests only indicate the microbiological quality of the pool water at the time of the test
- tests take a long time and the microbiological quality of the pool water may change while testing occurs

- a large volume of pool water is required for accurate analysis
- the sample of water may not be an accurate representation of the pool (*Cryptosporidiosis* can result from the ingestion of as few as one viable *Cryptosporidium parvum* particle).

Limit microbiological testing to bacterial indicators of faecal contamination such as *E. coli*.

To destroy any remaining protozoans in the pool and to combat *Cryptosporidiosis*, conduct super chlorination weekly or fortnightly. Super chlorination also has the benefit of reducing/ minimising any combined chlorines.

### Summary of microbial risks

In summary, the microbial risks of swimming pools increase as the pool depth become shallower and bather load increases. Figure 27 summarises the factors affecting microbial risk in swimming pools. Irrespective of the source and treatment of pool make-up water, the risk of microbial contamination in a pool can be managed by taking the following steps:

- Ensure water treatment complies with the requirements of the *NSW Public Health (Swimming Pools and Spa Pools) Regulation 2000*.
- Operate and maintain the disinfection system to the manufacturer’s recommendations. When disinfection problems occur that are unable to be resolved, seek the assistance of specialist pool disinfection consultants.

- Develop an isolation and treatment procedure for faecal contamination events and train staff.
- Use a UV or ozone system to provide extra disinfection and reduce chloramines.
- Adopt regular super chlorination of the pool on a weekly/fortnightly basis.

Advise patrons:

- not to swim within two weeks of having diarrhoea or vomiting.
- not to change nappies near the pool and to use a change room to wash their hands after changing a nappy.
- that non-toilet trained and incontinent bathers are to wear specially designed swimming pants.
- to use toilet facilities before entering pool.
- to take toddlers for regular toilet breaks during pool use.

NSW Health has also advised pool operators of steps to reduce risks to bathers using showers and toilets. For details, refer to *NSW Protocol for Minimising the Risk of Cryptosporidium Contamination in Public Swimming Pools and Spa Pools 1999*.

To reduce the risk of a *Cryptosporidiosis* outbreak:

- understand the risks of using alternative water sources for each type of pool
- carefully evaluate collection or treatment processes if alternative water sources are used for pool make-up
- prepare a risk assessment and management plan for using alternative water sources
- monitor make-up water quality before it is introduced into the pool
- monitor patron behaviour that can threaten pool water quality.

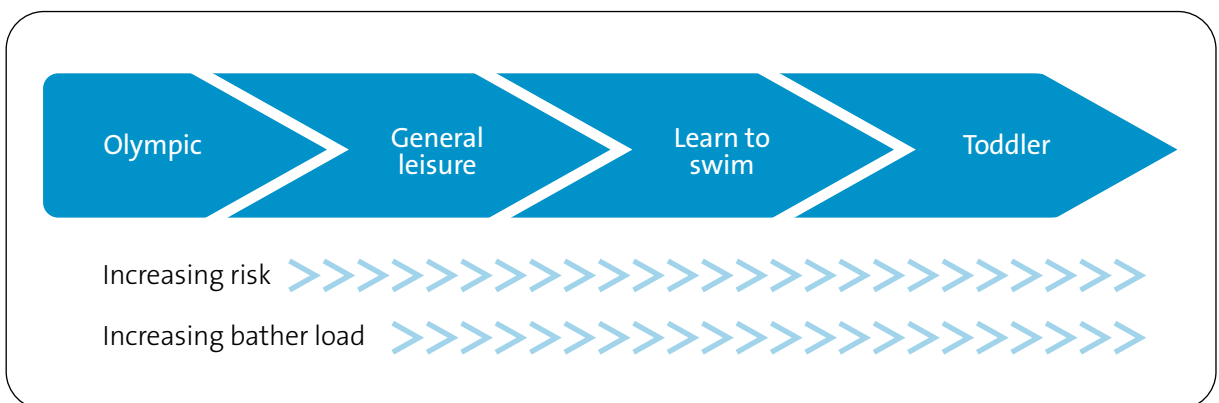

Figure 27 – General hierarchy of microbial risk in pools, based on pool type, pool design and equipment, and pool users

## Chapter 32

## Managing risks of using alternative sources of water

Drinking water can be replaced with an alternative water source. The source of the water determines the best use with the lowest risk.

Alternative sources of water:

- Bore water
- Rainwater
- Stormwater (not recommended for pool make-up)
- Filter backwash water
- Greywater sourced from showers/ washing machines (not recommended for pool make-up)
- Class A recycled water available from a local water authority's recycling plant (not recommended for pool make-up)

### Bore water

Provided that the bore water source can supply water that is close to drinking water quality, bore water can be used for the following applications with little pre-treatment:

- Toilet flushing
- Garden watering
- Wash down of surrounds
- Pool make-up

The quality of bore water varies from place to place and may change over time. As well as microorganisms, bore water may have physical or chemical

characteristics that limit where it can be used. Characteristics such as hardness and pH may affect the water balance in the pool when bore water is used for pool make-up.

Assess the quality of bore water before using it as an alternative to drinking water. Make sure the quality of the bore water is suitable for the end use.

### Collected rainwater

Rainwater can be collected and used to replace drinking water for the following applications:

- Toilet flushing
- Garden watering
- Wash down of pool surrounds
- Pool make-up

Additional information about using rainwater can be found in the NSW Health *Rainwater Tanks (2007)* brochure.

Rainwater tanks require periodic maintenance.

The use of rainwater as pool make-up is low risk, provided that the rain collection system is designed and maintained to the following recommendations:

- Rainwater must be introduced into the pool through the balance tank or overnight to make sure it has enough time for treatment before it comes into contact with bathers.
- Rainwater should be added to the pool before the pool filter to minimise any risk of dirt contamination in the pool. Consider installing a filter between the rainwater tank and the pool.
- Design rainwater collection with a first flush discard system. In between rain events, dirt, dust, leaves and rodent/bird droppings can build up on the rain collection area. When it rains, the build up is washed off first. The first flush system diverts the dirty water containing built up contaminants to the stormwater system, instead of the rainwater tank.
- Do not use collected rainwater within two hours of a rain event due to potential disturbances in the rainwater tanks.
- Ensure water treatment complies with the requirements of the *NSW Public Health (Swimming*

*Pools and Spa Pools) Regulation 2000* and enough free chlorine is available to treat introduced rainwater.

- Rainwater collected from the ground is classed as stormwater and has higher levels of contaminants. Stormwater is not recommended for use in the pool.

### Treated filter backwash water

Treated backwash water can be used for the following applications, if it is treated to an appropriate quality:

- Toilet flushing
- Garden watering (on-site)
- Watering of local sporting fields or nearby gardens
- Wash down of surrounds
- Pool make-up

The risk of using treated backwash varies, depending on the intended application and level of treatment. Potential risk for various applications is shown in Table 16.

### Risk associated with pool size and backwash water re-use

When using treated backwash water, the microbial risk to bathers varies, depending on the pool depth and the bather load of the source pool and the end use pool. A shallow pool has the highest risk to bathers and a deep pool has the lowest risk. Table 17 classifies the risk considering the source of the backwash water.

### Risk associated with backwash water re-use for pool make-up

Where treated backwash water is used for pool make-up, apply the following risk minimisation strategies:

- Validate the treatment process to ensure it provides the required water quality.
  - Conduct online monitoring of key parameters eg turbidity, free chlorine, pH.
  - Visually monitor pool for clarity and cloudiness.
  - Automatically divert backwash water if any of the water quality parameters are exceeded,
- for example redirect the treated backwash water to a holding tank when high turbidity is detected.
- Divert the first 10% of the backwash water to a holding tank to reduce the contaminant and microbiological load on your backwash water treatment system.
  - Operate and maintain the backwash treatment system to manufacturer’s specifications.
  - Reduce the inherent, introduced and operational factors contributing to microbial risk.

**Table 16 – Potential risk for re-using recycled backwash water in various applications**

Re-use	Potential risk
Garden irrigation (off-site)	Low
Toilet flushing (on-site)	Low
Irrigation (subsurface, on-site)	Low
Wash down of surrounds (on-site)	*Medium
Garden irrigation (on-site)	*Medium
Pool make-up	*High

\* Actual risk could be lower with sufficient controls or barriers in place

**Table 17 – Microbial risk of backwash water for bathers**

		Source of backwash water		
		Shallow/ small pool	Medium depth/ size pool	Deep/ large pool
End use for treated backwash water	Shallow pool	Very high risk	High risk	High risk
	Medium pool	High risk	Medium risk	Medium risk
	Deep pool	High risk	Medium risk	Low risk

### Backwash water re-use risk management table

The risks of using treated backwash water are summarised in the following table:

Risk	High risk	Medium risk	Low risk
<b>Source of pool backwash</b>	Shallow pools such as: <ul style="list-style-type: none"> <li>toddler</li> <li>learn-to-swim</li> </ul>	Medium depth pools such as: <ul style="list-style-type: none"> <li>family</li> <li>general purpose</li> <li>hydrotherapy</li> </ul>	Deep pools such as: <ul style="list-style-type: none"> <li>Olympic</li> <li>diving</li> </ul>
<b>End use for treated backwash water</b>	Shallow pools such as: <ul style="list-style-type: none"> <li>toddler</li> <li>learn-to-swim</li> </ul>	Medium depth pools such as: <ul style="list-style-type: none"> <li>family</li> <li>general purpose</li> <li>hydrotherapy</li> </ul>	Deep pools such as: <ul style="list-style-type: none"> <li>Olympic</li> <li>diving</li> </ul>
<b>Pool operation</b>	Manual control	Automated	Automated including pH & ORP (or chlorine probe) controls and alerts
<b>Pool maintenance</b>	Breakdown maintenance only	Non scheduled preventative maintenance combined with breakdown maintenance	Scheduled preventative maintenance by qualified staff eg pump servicing
<b>Pool super chlorination</b>	Monthly or less	Fortnightly	Weekly
<b>Backwash frequency</b>	Every month	Every fortnight	As determined by pressure drop across filter or weekly
<b>Backwash water treatment</b>	Settlement or filtration only	Settlement, filtration & disinfection	Advanced filtration & disinfection (reverse osmosis and ultraviolet light)
<b>Monitoring of backwash treatment process</b>	Monitoring of some treated batches	Periodic monitoring during process Water quality testing before discharge to pool	Online water quality monitoring eg particle counting/turbidity for microfiltration, conductivity for reverse osmosis Automatic diversion to wastewater if needed
<b>Overall risk classification</b>	If your re-use scheme matches any of the above, the classification is <b>High risk</b>	If your re-use scheme matches any of the above and does not match any of the high risks, the classification is <b>Medium risk</b>	If your re-use scheme matches all the above, the classification is <b>Low risk</b>

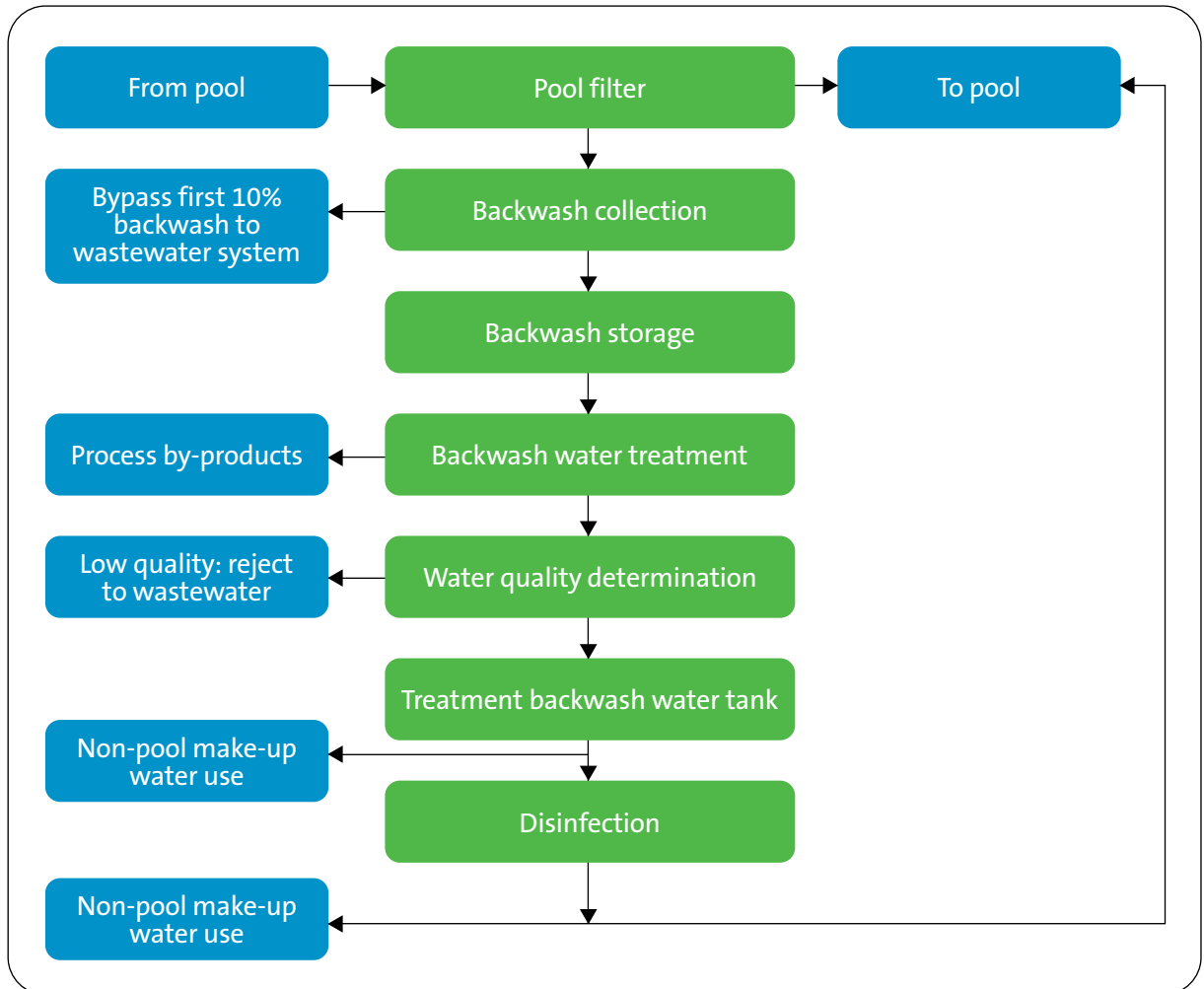
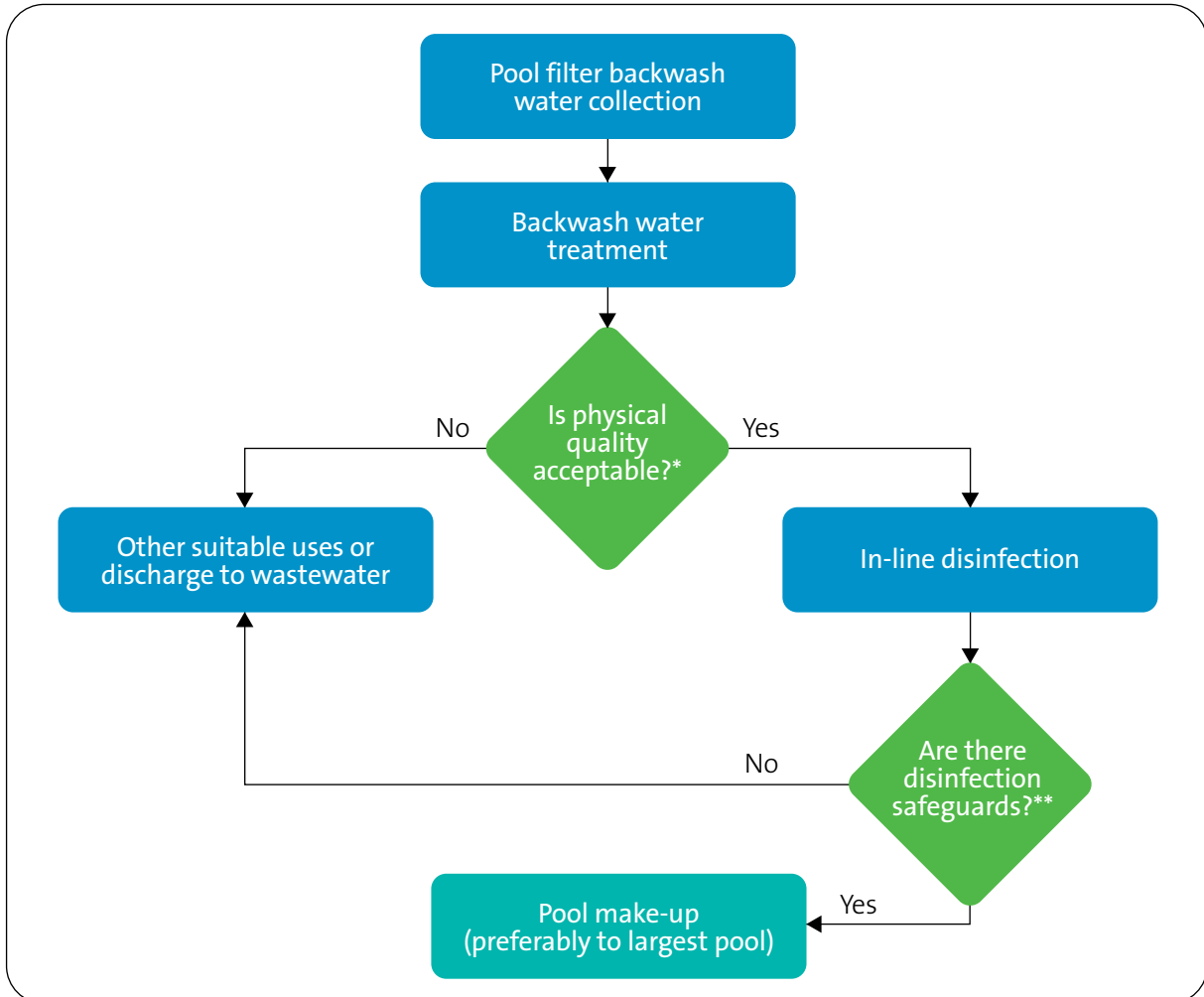

Figure 28 – Procedure for recovering pool backwash water



**Figure 29** – Deciding how to use treated backwash water

**\* Criteria for determination of physical water quality for re-use in pools**

- For RO systems, use online monitoring of conductivity.
- For other filtration systems, use online monitoring of suspended solids.

**\*\* Safeguards for in-line disinfection eg UV**

- Alarm for lamp failure.
- UV intensity measurements (online or regularly checked).
- Cleaning of UV tube sleeves when needed.
- Yearly replacement of lamps.

## Black or grey recycled water

Treated black (wastewater source) or grey water cannot be used for pool make-up. You can use treated black or grey recycled water to replace drinking water for:

- toilet flushing (Class A recycled water only)
- garden/landscape irrigation – where there is no direct contact with people.

*The Australian Guidelines for Water Recycling: Managing Health and Environmental Risks (Phase 1) (2006)* provide a useful reference for other uses for recycled water, including treated blackwater or greywater.

## Risks associated with using treated blackwater

While blackwater can be recycled to drinking water quality, it has not yet been accepted as a full substitute for drinking water where supplies are available. This is because it originates from wastewater.

Stringent testing of treated blackwater would be needed to establish its properties, particularly microbiological content, before it is accepted for use in pools by the state or federal health departments.

## Risks associated with using greywater

The risks associated with greywater include hair/lint and bacterial contents. To reduce these risks, the following processes should be applied as a minimum:

- Use a screen filter to remove any larger suspended solids from greywater.
- Greywater must be treated within 24 hours.
- Use drip or subsurface irrigation for gardens or sports fields.
- Do not use greywater for irrigating or cleaning near the pool. This stops greywater from being transferred into the pool.

Where greywater is used on a site, it must be contained within the site boundary. NSW Health, council and EPA approvals are required for greywater treatment systems.

## Case study

### Alternative water use at aquatic centres

Below is an analysis of risks and control measures used by some aquatic centres for alternative water sources.

Five of the aquatic centres that responded to a Sydney Water survey indicated they were using water from other sources. These centres (plus two other Sydney aquatic centres with backwash water recycling systems) were asked about their actual re-uses of water, their operational practices and how they manage risk.

- Five centres use treated backwash for pool make-up.
- One centre uses settled backwash water diluted with bore water for garden irrigation.
- One centre uses treated backwash water for toilet flushing and sometimes for cleaning.
- One centre uses rainwater (with UV treatment) for pool make-up.

For most pools, the backwash came from lower risk deeper pools. Some had higher risk sources including toddler pools, learn-to-swim pools and one had a spa pool.

The treated backwash water was mainly added to deeper pools with some addition into higher risk shallower pools. When the filter systems of shallow and deep pools were not independent, delivery into shallow pools could not be avoided.

Treatment of backwash water varied:

- Three centres discarded the first 10% of backwash water.
- Five centres used settlement tanks before treating and using backwash water. The time the backwash water was allowed to settle varied from a few hours to a day.
- Two centres used rainwater to dilute the backwash water – one before backwash treatment and the other after treatment.
- Four centres used reverse osmosis (RO) to treat backwash water. Only two centres monitored the resulting water quality. They measured the conductivity of the water or the pressure across the RO membranes. (This monitoring can be used to divert the water automatically to waste, if it does not meet the quality needed.)

Chlorine levels and contact time in the balance tanks for the treated water varied. Some centres also used extra treatment, such as UV.

These results show that aquatic centres need to:

- adopt a consistent approach for capturing, storing, treating, validating and using alternative water sources and their treatment systems
- prepare a risk assessment and management plan for using alternative water sources
- yearly review the water quality produced by the process at each site placing priority on pre-treating backwash water for use as pool make-up water.

It is clear that to control health risks associated with using alternate water sources in aquatic centres, risks need to be assessed and managed well.

## Chapter 33

## Risk matrixes for different types of pools

These risk matrixes provide a guide to the risk level of different types of pools, the risk factors that are present in each pool and the measures a pool operator can take to reduce the health risk to bathers from alternative water sources.

### Risk matrix for toddler pools

Risk level	Pool description	Risk factors	Preventative measures	Risk level after preventative measures
High	<ul style="list-style-type: none"> <li>Shallow and small volume</li> <li>Mainly toddler and baby users</li> </ul>	<ul style="list-style-type: none"> <li>Introduction of treated backwash water into toddler pool</li> </ul>	<ul style="list-style-type: none"> <li>Use treated backwash water for:               <ul style="list-style-type: none"> <li>watering the garden</li> <li>toilet flushing</li> <li>pool make-up for deeper pools</li> </ul> </li> </ul>	Risk eliminated
		<ul style="list-style-type: none"> <li>Introduction of rainwater into toddler pool</li> </ul>	<ul style="list-style-type: none"> <li>Install a first flush system to divert the first portion of captured water to drain</li> <li>Ensure there is rodent and bird control on rainwater tank and collection surface to prevent contamination</li> <li>Disinfect rainwater as a last barrier of protection from biological contamination</li> <li>Ensure chlorine residual is maintained in toddler pools at all times</li> </ul>	Low
		<ul style="list-style-type: none"> <li>Introduction of Class A recycled water (from wastewater source) into toddler pool</li> </ul>	<p><b>Recycled water must not be used for pool make-up</b></p> <ul style="list-style-type: none"> <li>Use Class A recycled water for:               <ul style="list-style-type: none"> <li>garden irrigation</li> <li>toilet flushing</li> </ul> </li> </ul>	Risk eliminated

## Risk matrix for toddler pools (continued)

Risk level	Pool description	Risk factors	Preventative measures	Risk level after preventative measures
High	<ul style="list-style-type: none"> <li>• Shallow and small volume</li> <li>• Mainly toddler and baby users</li> </ul>	<ul style="list-style-type: none"> <li>• Faecal or urine contamination of small volume pool               <ul style="list-style-type: none"> <li>– Users of pool may not have bladder or bowel control</li> <li>– Users may change nappies pool side</li> </ul> </li> <li>• Faecal contamination consumes free chlorine, which results in higher combined chlorine levels</li> </ul>	<ul style="list-style-type: none"> <li>• Advise patrons:               <ul style="list-style-type: none"> <li>– not to change nappies near the pool</li> <li>– not to swim within two weeks of having diarrhoea or vomiting</li> <li>– that non-toilet trained users are to wear specially designed swimming pants</li> <li>– to use toilet facilities before entering pool</li> <li>– to take toddlers for regular toilet breaks during pool use</li> </ul> </li> <li>• Ensure water treatment complies with the NSW <i>Public Health (Swimming Pools and Spa Pools) Regulation 2000</i></li> <li>• Use a UV or ozone system to provide extra disinfection and reduce chloramines</li> <li>• Develop an isolation and treatment procedure for faecal contamination events</li> </ul>	Medium
		<ul style="list-style-type: none"> <li>• Pool does not have its own filter and disinfection system</li> </ul>	<ul style="list-style-type: none"> <li>• Install separate pool filter and disinfection systems on toddler pools</li> </ul>	Medium

### Risk matrix for toddler pools (continued)

Risk level	Pool description	Risk factors	Preventative measures	Risk level after preventative measures
High	<ul style="list-style-type: none"> <li>Shallow and small volume</li> <li>Mainly toddler and baby users</li> </ul>	<ul style="list-style-type: none"> <li>Pool has a higher bather load making it difficult to maintain water balance</li> </ul>	<ul style="list-style-type: none"> <li>Ensure water treatment complies with the requirements of the NSW <i>Public Health (Swimming Pools and Spa Pools) Regulation 2000</i></li> <li>Conduct routine maintenance on pool filter and disinfection systems</li> <li>Monitor water quality and filter system performance</li> </ul>	Medium
		<ul style="list-style-type: none"> <li>Shallow outdoor toddler pools can lose chlorine from exposure to sunlight. This may reduce the free chlorine level to below minimum</li> </ul>	<ul style="list-style-type: none"> <li>Shade the toddler pool</li> <li>Monitor water quality and free chlorine levels</li> </ul>	Medium
		<ul style="list-style-type: none"> <li>Manual dosing of chlorine – poor control of free chlorine in pool</li> </ul>	<p><b>NSW Health Guidelines do not allow manual treatment of pools. A separate treatment system for each pool is recommended for better water balance control</b></p> <ul style="list-style-type: none"> <li>Install an automatic chlorine dosing system</li> <li>Monitor and control free chlorine at regular intervals, with increasing frequency during high bather loads</li> </ul>	Medium

### Risk matrix for learn-to-swim pools

Risk level	Pool description	Risk factors	Preventative measures	Risk level after preventative measures
High	<ul style="list-style-type: none"> <li>• Medium size</li> <li>• Pool users range in age from six months to adult learners</li> </ul>	<ul style="list-style-type: none"> <li>• Introduction of treated backwash water into learn-to-swim pool</li> </ul>	<ul style="list-style-type: none"> <li>• Use treated backwash water for:               <ul style="list-style-type: none"> <li>– watering the garden</li> <li>– toilet flushing</li> <li>– pool make-up for deeper pools</li> </ul> </li> </ul>	Risk eliminated
		<ul style="list-style-type: none"> <li>• Introduction of rainwater into learn-to-swim pool</li> </ul>	<ul style="list-style-type: none"> <li>• Introduce rainwater to the pool through the filters and balance tank</li> <li>• Install a first flush system to divert the first portion of captured water to drain</li> <li>• Ensure there is rodent and bird control on rainwater tank and collection surface to prevent contamination</li> <li>• Clean and maintain the rainwater tank regularly</li> <li>• Ensure chlorine residual is maintained in the learn-to-swim-pool</li> </ul>	Low
		<ul style="list-style-type: none"> <li>• Introduction of Class A recycled water (from wastewater source) into learn-to-swim pool</li> </ul>	<p><b>Recycled water must not be used for pool make-up</b></p> <ul style="list-style-type: none"> <li>• Use Class A recycled water for:               <ul style="list-style-type: none"> <li>– garden irrigation</li> <li>– toilet flushing</li> </ul> </li> </ul>	Risk eliminated

## Risk matrix for learn-to-swim pools (continued)

Risk level	Pool description	Risk factors	Preventative measures	Risk level after preventative measures
High	<ul style="list-style-type: none"> <li>• Medium size</li> <li>• Pool users range in age from six months to adult learners</li> </ul>	<ul style="list-style-type: none"> <li>• Faecal or urine contamination of medium volume pool               <ul style="list-style-type: none"> <li>– Users of pool may not have bladder or bowel control</li> <li>– Users may change nappies pool side</li> </ul> </li> <li>• Faecal contamination consumes free chlorine which results in higher combined chlorine levels</li> </ul>	<ul style="list-style-type: none"> <li>• Advise patrons:               <ul style="list-style-type: none"> <li>– not to change nappies near the pool</li> <li>– not to swim within two weeks of having diarrhoea or vomiting</li> <li>– that non-toilet trained users are to wear specially designed swimming pants</li> <li>– to use toilet facilities before entering pool</li> <li>– to take toddlers for regular toilet breaks during pool use</li> </ul> </li> <li>• Ensure water treatment complies with the requirements of the NSW <i>Public Health (Swimming Pools and Spa Pools) Regulation 2000</i></li> <li>• Use a UV or ozone system to provide extra disinfection and reduce chloramines</li> <li>• Develop an isolation and treatment procedure for faecal contamination events</li> </ul>	Low
		<ul style="list-style-type: none"> <li>• Pool has a higher bather load making it difficult to maintain water balance</li> </ul>	<ul style="list-style-type: none"> <li>• Ensure water treatment complies with the requirements of the NSW <i>Public Health (Swimming Pools and Spa Pools) Regulation 2000</i></li> <li>• Conduct routine maintenance on pool filter and disinfection systems</li> <li>• Monitor water quality and filter system performance</li> </ul>	Risk eliminated

### Risk matrix for learn-to-swim pools (continued)

Risk level	Pool description	Risk factors	Preventative measures	Risk level after preventative measures
High	<ul style="list-style-type: none"> <li>• Medium size</li> <li>• Pool users range in age from six months to adult learners</li> </ul>	<ul style="list-style-type: none"> <li>• Pool does not have its own filter and disinfection system</li> </ul>	<ul style="list-style-type: none"> <li>• Install separate pool filter and disinfection systems on learn-to-swim pools</li> </ul>	Medium

### Risk matrix for general purpose/leisure pools

Risk level	Pool description	Risk factors	Preventative measures	Risk level after preventative measures
Medium	<ul style="list-style-type: none"> <li>• Medium to large</li> <li>• Patrons of all ages.</li> </ul>	<ul style="list-style-type: none"> <li>• Pool has a lower user to volume ratio than the higher risk pools above</li> <li>• Pool can be more easily controlled to within set points than the above pools</li> </ul>	<ul style="list-style-type: none"> <li>• Ensure water treatment complies with the requirements of the <i>NSW Public Health (Swimming Pools and Spa Pools) Regulation 2000</i></li> <li>• Conduct routine maintenance on pool filter and disinfection systems</li> <li>• Monitor water quality and filter system performance</li> </ul>	Low
		<ul style="list-style-type: none"> <li>• Introduction of treated backwash water into general purpose/leisure pool</li> </ul>	<ul style="list-style-type: none"> <li>• Use treated backwash water for: <ul style="list-style-type: none"> <li>– watering the garden</li> <li>– toilet flushing</li> <li>– pool make-up for deeper pools</li> </ul> </li> </ul>	Risk eliminated

### Risk matrix for general purpose/leisure pools (continued)

Risk level	Pool description	Risk factors	Preventative measures	Risk level after preventative measures
Medium	<ul style="list-style-type: none"> <li>• Medium to large</li> <li>• Patrons of all ages.</li> </ul>	<ul style="list-style-type: none"> <li>• Introduction of rainwater into general purpose/leisure pool</li> </ul>	<ul style="list-style-type: none"> <li>• Introduce rainwater to the pool through the filters and balance tank</li> <li>• Install a first flush system to divert the first portion of captured water to drain</li> <li>• Ensure there is rodent and bird control on rainwater tank and collection surface to prevent contamination</li> <li>• Clean and maintain the rainwater tank regularly</li> <li>• Ensure chlorine residual is maintained in the general purpose/leisure pool</li> </ul>	Low
		<ul style="list-style-type: none"> <li>• Introduction of Class A recycled water into general purpose/leisure pool</li> </ul>	<ul style="list-style-type: none"> <li>• <b>Recycled water must not be used for pool make-up</b></li> <li>• Use Class A recycled water for:               <ul style="list-style-type: none"> <li>– garden irrigation</li> <li>– toilet flushing</li> </ul> </li> </ul>	Risk eliminated
		<ul style="list-style-type: none"> <li>• Disinfection system failure</li> </ul>	<ul style="list-style-type: none"> <li>• Ensure water treatment complies with the requirements of the <i>NSW Public Health (Swimming Pools and Spa Pools) Regulation 2000</i></li> <li>• Conduct routine maintenance</li> <li>• Monitor water quality</li> </ul>	Low
		<ul style="list-style-type: none"> <li>• Filtration system failure</li> </ul>	<ul style="list-style-type: none"> <li>• Conduct routine maintenance</li> <li>• Monitor filter system performance</li> </ul>	Low

## Risk matrix for Olympic pools

Risk level	Pool description	Risk factors	Preventative measures	Risk level after preventative measures
Low	<ul style="list-style-type: none"> <li>• Large volume</li> <li>• Patrons of all ages – predominately adults</li> </ul>	<ul style="list-style-type: none"> <li>• Low user to volume ratio enables best control of pool set points</li> <li>• Low usage of pool by younger patrons reduces contamination</li> </ul>	<ul style="list-style-type: none"> <li>• No preventative measures necessary</li> </ul>	Low
		<ul style="list-style-type: none"> <li>• Introduction of treated backwash water into Olympic pool</li> </ul>	<ul style="list-style-type: none"> <li>• Ensure backwash treatment system achieves required water quality</li> <li>• Ensure water treatment complies with the requirements of the <i>NSW Public Health (Swimming Pools and Spa Pools) Regulation 2000</i></li> <li>• Online monitoring of backwash water quality (eg turbidity). Water to be diverted if out of specification</li> <li>• Routine maintenance of backwash treatment system</li> <li>• Regular testing of treated backwash water quality. Water to be diverted and an investigation to be carried out if water found to be out of specification.</li> </ul>	Low

### Risk matrix for Olympic pools (continued)

Risk level	Pool description	Risk factors	Preventative measures	Risk level after preventative measures
Low	<ul style="list-style-type: none"> <li>Large volume</li> <li>Patrons of all ages – predominately adults</li> </ul>	<ul style="list-style-type: none"> <li>Introduction of rainwater into Olympic pool</li> </ul>	<ul style="list-style-type: none"> <li>Introduce rainwater to the pool through the filters and balance tank</li> <li>Install a first flush system to divert the first portion of captured water to drain</li> <li>Ensure there is rodent and bird control on rainwater tank and collection surface to prevent contamination</li> <li>Clean and maintain the rainwater tank regularly</li> <li>Ensure chlorine residual is maintained in the Olympic pool</li> </ul>	Low
		<ul style="list-style-type: none"> <li>Introduction of Class A recycled water (from wastewater source) into Olympic Pool</li> </ul>	<p><b>Recycled water must not be used for pool make-up</b></p> <ul style="list-style-type: none"> <li>Use Class A recycled water for:               <ul style="list-style-type: none"> <li>garden irrigation</li> <li>toilet flushing</li> </ul> </li> </ul>	Risk eliminated
		<ul style="list-style-type: none"> <li>Disinfection system failure</li> </ul>	<ul style="list-style-type: none"> <li>Ensure water treatment complies with the requirements of the <i>NSW Public Health (Swimming Pools and Spa Pools) Regulation 2000</i></li> <li>Conduct routine maintenance</li> <li>Monitor water quality</li> </ul>	Low
		<ul style="list-style-type: none"> <li>Filtration system failure</li> </ul>	<ul style="list-style-type: none"> <li>Conduct routine maintenance</li> <li>Monitor filter system performance</li> </ul>	Low





# Appendix 2

## Water saving checklist

Appendix 2 of ***Best practice guidelines for water management in aquatic leisure centres*** is aimed at aquatic centre managers and pool operators. This practical checklist will help you identify practical opportunities for water efficiency in your aquatic centre.

Managing your water	Yes/No	Recommended action
Do you monitor and record your water use?	Yes <input type="checkbox"/> No <input type="checkbox"/>	If No, read your meter at least daily, or install a continuous monitoring system (Chapter 6). Record meter reading information so you can identify changes in water use.
Do you benchmark your water use?	Yes <input type="checkbox"/> No <input type="checkbox"/>	If No, calculate a L/bather or L/patron figure and compare it to other aquatic centres and the benchmarks supplied in this guide (Chapter 2).
Do you know where water is used in your aquatic centre?	Yes <input type="checkbox"/> No <input type="checkbox"/>	If No, look at the average water use figures in Chapter 1 for guidance. Install submeters according to the priorities in Chapter 6 to develop your own water balance (Chapter 8).
Do you know where the best opportunities to save water are?	Yes <input type="checkbox"/> No <input type="checkbox"/>	If No, perform a water audit as described in Chapter 7: <ul style="list-style-type: none"> <li>• Check for leaks</li> <li>• Check swimming pool operations</li> <li>• Check amenities, kiosks, other areas of your centre and identify where efficiencies can be made</li> <li>• Develop a water balance for your centre (Chapter 8) and see where you are using most water.</li> </ul>
Do you regularly review your centre's water and energy management?	Yes <input type="checkbox"/> No <input type="checkbox"/>	If No: <p>Use the template provided in the <i>NSW Water and Energy Savings Action Plan guidelines</i> at: <a href="http://www.environment.nsw.gov.au/sustainbus/savingsactionplans.htm">www.environment.nsw.gov.au/sustainbus/savingsactionplans.htm</a></p> <p>Compare your results to previous reviews and rate your achievement of critical actions.</p>
Do you regularly review your submeters, or information from your continuous monitoring system?	Yes <input type="checkbox"/> No <input type="checkbox"/>	If No, establish work procedures so that a member of staff is responsible for analysing water use information and knows what to do if water use changes.

Do you know how much water, and associated charges (energy, pumping, chemical, wastewater discharge), are costing your business?	Yes <input type="checkbox"/> No <input type="checkbox"/>	If No, refer to the guide's information about the true cost of water in Chapter 4. Calculate your centre's water costs and associated charges. Knowing your water costs will help you justify water efficiency projects.
Have you developed a water management plan?	Yes <input type="checkbox"/> No <input type="checkbox"/>	If No, look at the results from this checklist and your water audit, then develop a water balance and a resource management plan (Chapter 9).
Do you have signs, posters and stickers in your centre to encourage water efficiency and remind people to report leaks?	Yes <input type="checkbox"/> No <input type="checkbox"/>	If No, Sydney Water's Business Customer Program has examples of stickers, posters and shower hangers you can use at <a href="http://sydneywater.com.au">sydneywater.com.au</a>

Amenities	Yes/No	Recommended action
Have you installed submeters on supply lines to amenities and hot water supply?	Yes <input type="checkbox"/> No <input type="checkbox"/>	If No, install submeters on supply lines to amenities (Chapter 6). Conduct routine inspections, monitor water use, and schedule maintenance checks to detect problems before they become large leaks.
Does your centre have any cyclic flushing urinals?	Yes <input type="checkbox"/> No <input type="checkbox"/>	If Yes, replace with manually flushing urinals, automatic sensor units or ultra low-flow or waterless urinals. Refer to Chapter 17 for more information.
Does your centre have automatic on-demand urinal sensor flushing systems?	Yes <input type="checkbox"/> No <input type="checkbox"/>	If Yes, regularly check that sensors are working properly and not detecting unrelated movements. Check that solenoids are operating correctly and replace them if they are faulty or worn.
Does your centre have single flush toilets?	Yes <input type="checkbox"/> No <input type="checkbox"/>	If Yes, replace single flush toilets in high use areas with 6/3 L or 4.5/3 L dual flush models. If toilets are in low use areas, restrict cistern volume and bring forward programmed replacement.
Does your centre have dual-flush toilets?	Yes <input type="checkbox"/> No <input type="checkbox"/>	If Yes, check the flush capacity. Older 11/5.5 L and 9/4.5 L dual flush toilets can be replaced with new 6/3 L or 4.5/3 L flush models.
Are cistern rubber seals on toilets replaced regularly?	Yes <input type="checkbox"/> No <input type="checkbox"/>	If No, cistern rubber seals should be replaced at least every two years to prevent leaks.

Do you have a flusherette system?	Yes <input type="checkbox"/> No <input type="checkbox"/>	If Yes, check the flow rate and flush timing. Over time, wear will cause excessive flush volumes. Insert flow regulators into valve bodies to reduce flow.
Do you have flow regulators in all hand basins?	Yes <input type="checkbox"/> No <input type="checkbox"/>	If No, install flow regulators to reduce flow to at least 6 L/min.
Do you have water efficient showers?	Yes <input type="checkbox"/> No <input type="checkbox"/>	If No, install flow regulators to reduce flow to at least 9 L/min or install WELS 3 star rated showerheads.

Swimming pool operations	Yes/No	Recommended action
Is there a water meter on the make-up water pipe?	Yes <input type="checkbox"/> No <input type="checkbox"/>	If No, install a submeter and monitor water use regularly.
When the pump is stopped, does water flow from the overflow drain pipe?	Yes <input type="checkbox"/> No <input type="checkbox"/>	If Yes, check that the drain valve is correctly set and if there are any leaks. Check if the valve is closed and adequately sealed.
When the pump is stopped, does water flow from the overflow drain pipe while the water is coming in through the make-up water line?	Yes <input type="checkbox"/> No <input type="checkbox"/>	If Yes, this indicates that the ball float or solenoid valve is incorrectly set. Reset the ball float valve.
Do any pumps have packed gland pump seals?	Yes <input type="checkbox"/> No <input type="checkbox"/>	If Yes, ensure pumps are inspected monthly and seals tightened as needed. Also consider replacing the seals with mechanical seals to minimise leaks.
Does your water treatment contractor clean the conductivity sensors every month?	Yes <input type="checkbox"/> No <input type="checkbox"/>	If No, make this part of their ongoing duties. Ensure sensors are recalibrated every month.

Heating and ventilation systems and centre design	Yes/No	Recommended action
Does your aquatic centre have cooling towers?	Yes <input type="checkbox"/> No <input type="checkbox"/>	If yes, refer to Sydney Water's <i>Best practice guidelines for cooling towers in commercial buildings</i> to help you minimise cooling tower water use.

Have you integrated economy cycle or fresh air venting into your heating and ventilation system?	Yes <input type="checkbox"/> No <input type="checkbox"/>	If No, investigate if this can be done with your current HVAC equipment.
Have you reduced the heat load in your centre as far as possible?	Yes <input type="checkbox"/> No <input type="checkbox"/>	If No, install energy efficient lighting, centre insulation, external shading, high performance insulation, sympathetic landscaping, and heat efficient natural lighting.
Have you considered other HVAC systems?	Yes <input type="checkbox"/> No <input type="checkbox"/>	If No, investigate options including thermal wheels or cross flow heat exchangers. These are viable alternatives to traditional HVAC systems and should be investigated when upgrading or renovating.

Kitchens and kiosks	Yes/No	Recommended action
Are the water supply lines to your kitchen or kiosk submetered?	Yes <input type="checkbox"/> No <input type="checkbox"/>	If No, install submeters on the supply lines to food areas (Chapter 6) and monitor water use regularly.
Is the hot water system supplying your kitchen or kiosk located near these areas?	Yes <input type="checkbox"/> No <input type="checkbox"/>	If No, consider installing a separate hot water system closer to your kitchen, insulating the hot water supply line or installing a 'ring main' or loop system to prevent water waste and reduce energy costs.
Do you have flow regulators on kitchen sinks and basins?	Yes <input type="checkbox"/> No <input type="checkbox"/>	If No, install 9 or 12 L/min flow restrictors on kitchen sinks and 6 L/min restrictors on hand basins.
Do you have a water efficient dishwasher?	Yes <input type="checkbox"/> No <input type="checkbox"/>	If No, replace your existing model with a water efficient model. You will save money through water and energy savings.
Do staff operate dishwashers efficiently?	Yes <input type="checkbox"/> No <input type="checkbox"/>	If No, ensure relevant staff are trained in efficient dishwasher operation.
Do staff in kitchens and kiosks rinse plates before washing?	Yes <input type="checkbox"/> No <input type="checkbox"/>	If Yes, install water efficient 6 L/min WELS rated pre rinse spray valves.
Do you check the condition of pre-rinse spray valves?	Yes <input type="checkbox"/> No <input type="checkbox"/>	If No, inspect pre-rinse spray valves every two weeks to check for leaks and worn valves. Worn valves waste water and reduce cleaning efficiency.

Do staff in kitchens and kiosks leave taps running while they are cooking and cleaning?	Yes <input type="checkbox"/> No <input type="checkbox"/>	If Yes, install signs to remind staff to turn off taps. Consider installing sensor taps or foot operated taps.
Are kitchen floors hosed down?	Yes <input type="checkbox"/> No <input type="checkbox"/>	If Yes, consider using mops or squeegees instead of hoses. If hoses must be used, ensure they are fitted with trigger nozzles.
Is food ever defrosted under running water?	Yes <input type="checkbox"/> No <input type="checkbox"/>	If Yes, ensure all food is defrosted in a refrigerator, or in a microwave if it is to be cooked immediately.

Fitness centres	Yes/No	Recommended action
Does your centre have a fitness centre?	Yes <input type="checkbox"/> No <input type="checkbox"/>	If Yes, continue with this section. If No, go to the next section.
Are the showers water efficient?	Yes <input type="checkbox"/> No <input type="checkbox"/>	If No, install flow regulators so that flow is reduced to at least 9 L/min or install WELS 3 star rated showerheads.
Do you have flow regulators in all hand basins?	Yes <input type="checkbox"/> No <input type="checkbox"/>	If No, install flow regulators so that flow is reduced to 6 L/min or less.

Outdoor areas and water features	Yes/No	Recommended action
Do you have a landscaped area or water features?	Yes <input type="checkbox"/> No <input type="checkbox"/>	If Yes, continue with this section.
Do you submeter your irrigation supply and water features?	Yes <input type="checkbox"/> No <input type="checkbox"/>	If No, consider installing submeters (Chapter 6) to determine your water use and identify leaks. This is especially important if you have large irrigated areas or large water features.
Do you improve your soils?	Yes <input type="checkbox"/> No <input type="checkbox"/>	Improving soil quality can improve plant growth and water retention. Refer to Chapter 21 for garden and landscaping tips.
Do you use an alternative water source to irrigate your garden?	Yes <input type="checkbox"/> No <input type="checkbox"/>	If No, consider using rainwater, bore water or treated wastewater for irrigation (Part 4).

Cleaning	Yes/No	Recommended action
Do you communicate with cleaning staff regularly?	Yes <input type="checkbox"/> No <input type="checkbox"/>	If No, cleaning staff will need information about water wise cleaning techniques and the correct way to clean specialised equipment such as waterless urinals. You can use Sydney Water factsheets available at <a href="http://sydneywater.com.au">sydneywater.com.au</a> , to communicate with staff.
Do cleaners hose down areas within your centre?	Yes <input type="checkbox"/> No <input type="checkbox"/>	If Yes, use brooms or mops to clean floors, or use rainwater or other water sources if you must use the hose. Ensure hoses have water efficient trigger nozzles.

## Glossary

<b>Alkalinity</b>	The acid-neutralising capacity of water, otherwise known as buffering capacity. It is the sum of the titratable bases in a sample.
<b><i>Australian Drinking Water Guidelines (ADWG)</i></b>	The guidelines summarise the criteria for identifying acceptable drinking water quality.
<b>Backflow</b>	Flow in a direction against the normal or intended direction, such as the unintended flow of water from a potentially polluted source into a drinking water supply.
<b>Backflow prevention containment device</b>	A device to prevent the reverse flow of water from a potentially polluted source into the drinking water supply.
<b>Backwash</b>	The process of cleaning a filter by forcing air and water upwards through it, flushing out trapped waste material.
<b>Ball float valve</b>	A valve that is controlled by a ball float and used to monitor the level of water in a swimming pool balance tank. This regulates the flow of make-up water to maintain the water level in the swimming pool.
<b>Beneficial re-use</b>	Recovering used materials to subsequently deliver a net environmental benefit.
<b>Biodegradable</b>	A substance that can be broken down into harmless products in the environment.
<b>Blackwater</b>	Untreated wastewater, including water from a toilet.
<b>Bleed</b>	Removing water from a swimming pool to limit the concentration of total dissolved solids and suspended solids.
<b>Chlorination</b>	The application of chlorine to drinking water, wastewater, or industrial waste to disinfect or to oxidise undesirable compounds.
<b>Chlorine (Cl)</b>	A naturally occurring element. To ensure good quality water, chlorine is added to kill bacteria that may cause disease. Residual chlorine must be present to make sure that the water is disinfected. The health guideline value for chlorine residual depends on the type of chlorine used.
<b>Coagulation</b>	The addition of a coagulant chemical to destabilise the charges of a particulate suspended in water, collapsing the negatively charged 'cloud' surrounding the particle so they can settle out.
<b>Coliforms (total)</b>	Total coliform bacteria are used as a scientific indicator of the quality of drinking water and of the possible presence of disease causing microorganisms. They are measured in colony forming units per 100 mL.

<b>Colony Forming Unit (cfu)</b>	Unit that represents the number of bacteria.
<b>Conservation</b>	Managing resources to prevent and reduce wasteful, uneconomical, impractical or unreasonable use of resources.
<b>Cross connection</b>	Any connection or arrangements between the drinking water supply system, connected to the water main or any fixture that may enable non-drinking water or other contamination to enter the drinking water supply system.
<b><i>Cryptosporidiosis</i></b>	A disease people develop from ingesting <i>Cryptosporidium</i> oocysts.
<b><i>Cryptosporidium (crypto.)</i></b>	Microorganisms in warm-blooded animals that sometimes enter the water supply. Disinfection and treatment processes normally kill or remove them.
<b>Dechlorination</b>	A process that neutralises the toxicity of chlorine and chloramines (a by-product of chlorine).
<b>Desalination</b>	The process that removes salt from saline water to produce fresh water.
<b>Disinfection</b>	Using chemical or physical processes to kill pathogens or organisms that are capable of causing infectious disease.
<b>Drinking water</b>	Water intended primarily for human consumption, but which has other domestic and commercial uses.
<b>Dual reticulation</b>	A water supply system that provides two grades of water through separate pipe networks. High quality drinking water is delivered through one pipe network, and recycled water is delivered through the second pipe network. Recycled water is used in gardens, for flushing toilets, and for other non-drinking uses.
<b><i>E. coli (Escherichia coli)</i></b>	A type of thermo-tolerant coliform bacteria, usually present in the gut of warm-blooded animals. It is generally the most specific indicator of faecal contamination.
<b>Ecologically Sustainable Development (ESD)</b>	Development that improves the quality of life, both now and in the future, and maintains ecological processes.
<b>Emission</b>	Anything given off (such as gases, heat and odours) as a result of a process.
<b>EMP</b>	Environmental Management Plan.
<b>Evaporation</b>	Liquid water converted by the sun to water vapour that returns into the atmosphere as a gas.
<b>Faecal coliforms</b>	Bacteria in the intestines of humans and other vertebrates and present in faeces.

<b>Filtration</b>	A process for removing particles from a solution by passing it through a porous structure or medium, such as a screen, membrane, sand or other filtration media.
<b>Flocculant</b>	A chemical that encourages heavy contaminants to gather together and settle from water more quickly in the treatment process.
<b>Flocculation</b>	The process of using chemical flocculants.
<b><i>Giardia</i></b>	Microorganisms in warm-blooded animals that may enter the water supply. Disinfection and treatment processes normally kill them.
<b>Gigajoule (GJ)</b>	A measure of energy equal to a billion joules.
<b>Gigalitre (GL)</b>	A measure of volume equal to a billion litres.
<b>Grease arrestor</b>	A pre-treatment device that separates oil, grease and suspended solids from wastewater by gravity, before it enters the wastewater system.
<b>Greenhouse gas emissions</b>	The release of greenhouse gases into the atmosphere. Greenhouse gases include carbon dioxide that is released when fossil fuels such as coal, oil and natural gas are burnt to produce energy.
<b>Greywater</b>	Domestic wastewater from sources other than toilets, such as washing machines and dishwashers.
<b>Groundwater</b>	Water found below the earth's surface, usually in porous rock or soil or in underground aquifers (natural underground formations with significant quantities of water).
<b>HVAC</b>	Heating, ventilation and air conditioning.
<b>Individual backflow protection</b>	A backflow prevention device at the water connection to a fixture or appliance.
<b>Irrigation</b>	Controlled application of water through manmade systems to supply the water requirements of plants.
<b>Kilolitre (kL)</b>	One thousand litres or one tonne of water.
<b>Litre (L)</b>	A measure of liquid volume.
<b>Master water meter</b>	A water meter owned by Sydney Water, located at the property boundary on the water supply to that property.
<b>Maximum</b>	The highest measure recorded.
<b>Median</b>	The middle reading in a series.

<b>Megalitre (ML)</b>	Measurement of volume equal to one million litres. One megalitre is about the volume of a one-metre deep Olympic-sized swimming pool.
<b>Microfiltration</b>	A pressure-driven membrane operation in which very fine particles or other suspended matter is separated from a liquid. It can remove suspended solids, bacteria or other impurities. Membrane pore sizes are slightly larger than those used for ultrafiltration.
<b>Microgram</b>	Unit of measurement equivalent to 0.001 of a milligram.
<b>Microgram per litre (<math>\mu\text{g/L}</math>)</b>	Unit of measurement equivalent to 0.001 of a milligram expressed per litre.
<b>Microorganisms</b>	The organisms that are invisible or only barely visible to the unaided eye.
<b>Milligram (mg)</b>	Unit of measurement equivalent to 0.001 of a gram.
<b>Milligrams per litre (mg/L)</b>	Unit of measurement equivalent to 0.001 of a gram expressed per litre.
<b>Millilitre (mL)</b>	Unit of measurement that is equivalent to 0.001 of a litre.
<b>Minimum</b>	The lowest recorded reading.
<b>Monitoring</b>	An ongoing testing program to assess potential changes in circumstances.
<b>Mud balling</b>	When sand media in a filter becomes coated in sediment, reducing the effectiveness of water filtration.
<b>Nephelometric Turbidity Unit (NTU)</b>	Unit of scientific measurement used to show the level of suspended material in solution.
<b>Non-potable re-use</b>	The use of treated wastewater for purposes that do not require water of a drinkable standard.
<b>OH&amp;S</b>	Occupational health and safety for all worksite staff, contractors and visitors.
<b>Organic</b>	Animal or vegetable in origin.
<b>Osmosis</b>	Movement of water molecules through a thin membrane from an area of high concentration to an area of low concentration.
<b>Ozonation</b>	Using ozone for water disinfection.
<b>Ozone</b>	A form of oxygen with three rather than the normal two oxygen atoms. A strong oxidising agent.
<b>Parasite</b>	An organism that relies on a host organism to survive.

<b>Pathogens</b>	Potentially disease-causing microorganisms including bacteria, viruses, parasitic protozoa (such as <i>Giardia</i> and <i>Cryptosporidium</i> ) and Helminthes (such as intestinal worms).
<b>Per capita</b>	For each head of population.
<b>pH</b>	A measure of the alkalinity or acidity of water on a scale from 1 to 14: 1 is most acidic, 7 neutral and 14 most alkaline.
<b>Potable re-use</b>	Re-use of highly treated wastewater for drinking.
<b>Potable</b>	Fit or suitable water for drinking.
<b>Pre-rinse spray valve</b>	A handheld nozzle used to remove food scraps from dishes before they are washed.
<b>Rainwater tank</b>	On-site storage to collect rainwater for beneficial use.
<b>Recycled water</b>	Highly treated wastewater for use in industrial processes including cooling towers, irrigation in agriculture, urban parks and landscapes, and household use such as flushing toilets, car washing and watering gardens. It is not for drinking or personal use.
<b>Recycling</b>	Collecting and reprocessing a resource so it can be used again.
<b>Renewable resource</b>	A resource that is replenished at the same rate it is used.
<b>Reverse osmosis</b>	A process where pressure is put on the concentrated side of a liquid system, in which liquids with different concentrations of mineral salts are separated by a semi-permeable membrane. Molecules of pure water then pass out of the concentrated solution into the weak or fresh water side. The reverse osmosis membrane is permeable to the solvent, but impermeable to most dissolved species, both organic and inorganic.
<b>Risk assessment</b>	Process of gathering data and making assessments to estimate short and long-term harmful effects on human health or the environment from exposure to hazards associated with a particular product or activity.
<b>Scum</b>	Material that floats to the surface of wastewater during treatment, usually removed in sedimentation tanks.
<b>Sediment</b>	Soil or other particles that settle to the bottom of lakes, rivers, oceans and other water.
<b>Sedimentation</b>	A treatment process that allows sediment to settle out of water or wastewater.
<b>Sewage</b>	See wastewater.
<b>Sewerage system</b>	See wastewater system.
<b>Soluble</b>	Able to be dissolved in water.

<b>Solenoid</b>	An electro mechanical device that activates a valve.
<b>Splash out</b>	In swimming pools, the water that can be lost when bathers splash water out of the pool or carry water out when they exit the pool.
<b>Stakeholder</b>	A stakeholder is any individual or group that can affect or be affected by an organisation's activities.
<b>Stormwater</b>	Rainwater that runs off the land, frequently carrying various forms of pollution such as litter and detritus, animal droppings and dissolved chemicals. This untreated water is carried in stormwater channels and discharged directly into creeks, rivers, the harbour and the ocean.
<b>SUDF</b>	Sewerage Usage Discharge Factor is a measure of the ratio of water going out of your business through the wastewater system compared to water coming in from Sydney Water mains.
<b>Suspended solids</b>	Particles in water that can be removed by sedimentation or filtration.
<b>Sustainable water supply</b>	A water supply system that has achieved a long-term balance between capturing and storing supplies of water and meeting the demand of current and future users, including the environment.
<b>Thermo-tolerant coliforms</b>	A coliform that can survive at higher temperatures than other total coliforms, also known as faecal coliforms.
<b>Total coliforms (TCs)</b>	Bacteria commonly found in the environment and intestines of warm-blooded animals. <i>E. coli</i> is seen as a more important public health organism indicator.
<b>Total dissolved solids (TDS)</b>	A measure of the salinity in water. Expressed in mg/L. Typically, conductivity is used as an indicator of TDS.
<b>Trade waste</b>	Industrial or commercial wastewater discharged to the wastewater system with significant potential contaminants. The volume and concentration of contaminants discharged to the wastewater system is usually limited by trade waste agreements.
<b>Trade waste agreements</b>	Agreements between Sydney Water and industrial and commercial customers to restrict the amount of toxic and other potentially harmful substances discharged to the wastewater system.
<b>Treatment (water)</b>	The process of removing contaminants, conditioning and disinfecting water to achieve a desired level of quality.

<b>Trihalomethanes (THMs)</b>	Formed in water when chlorine reacts with small amounts of naturally occurring organic matter and measured in mg/L.
<b>Turbidity</b>	The presence of suspended material in water that may cause it to look cloudy or discoloured. It is measured in NTUs.
<b>Ultrafiltration</b>	A high level filtration for water and wastewater treatment that uses very fine pore size membranes to allow selective particles to pass through. It can remove suspended solids, bacteria and viruses. Membrane pore sizes are slightly smaller than those used for microfiltration.
<b>Unaccounted for water</b>	The difference between water measured when entering the water supply system and customer use. It occurs because of leaks, inaccurate metering and illegal use.
<b>UV</b>	Ultraviolet light, a high-energy light used for disinfection.
<b>Waste</b>	Discarded, rejected, unwanted, surplus or abandoned substances. Does not include gas, water, wastewater, and beneficially used biosolids and re-use water.
<b>Wastewater</b>	The wastewater from homes, offices, shops, factories and other premises discharged to the wastewater system. About 99% of wastewater is water.
<b>Wastewater system</b>	The system of pipes and pump stations for collecting and transporting wastewater from each property to the wastewater treatment plant or water recycling plant.
<b>Water demand</b>	Total water use requirements for drinking, agriculture, industry, recreation and gardening. Demand is seasonal and highly influenced by the weather.
<b>Water efficiency</b>	Preventing and reducing wasteful, uneconomical, impractical or unreasonable use of water resources.
<b>Water quality</b>	The physical, chemical and biological characteristics in the water.
<b>Water re-use</b>	Using water more than once, following treatment of wastewater to an appropriate quality standard and delivery to the point of use.
<b>WELS</b>	Water Efficient Labelling Scheme. As part of the Water Efficient Labelling and Standards Program, WELS gives products a star rating according to their water efficiency.
<b>Zone protection</b>	Installing a backflow prevention device at the connection point of specified sections of a plumbing system, within a building or facility.



## Contact us

[sydneywater.com.au](http://sydneywater.com.au)

### Enquiries

Call 13 20 92

### Service difficulties and emergencies

Call 13 20 90

### Postal address

Sydney Water

PO Box 399

Parramatta NSW 2124



Water  life  
NSW GOVERNMENT